

DATA HANDBOOK

Vidicon and Newvicon Camera Tubes and Deflection Units

B | 0 | 0 | K | P | C | 0 | 7 | 1 | 9 | 8 | 9

Philips Components



PHILIPS

**VIDICON AND NEWVICON CAMERA TUBES
AND DEFLECTION UNITS**

	<i>page</i>
Vidicon tubes	
Survey and type selection	4
General operational notes	5
Device data.	9
 Newvicon tubes	
Survey and type selection	76
General operational notes	77
Device data.	81
 Deflection units	
Device data.	155
 Index of type numbers.	179

RATING SYSTEM

(in accordance with IEC Publication 134)

ABSOLUTE MAXIMUM RATING SYSTEM

Absolute maximum ratings are limiting values of operating and environmental conditions applicable to any electronic device of a specified type as defined by its published data, which should not be exceeded under the worst probable conditions.

These values are chosen by the device manufacturer to provide acceptable serviceability of the device, taking no responsibility for equipment variations, environmental variations, and the effects of changes in operating conditions due to variations in the characteristics of the device under consideration and of all other electronic devices in the equipment.

The equipment manufacturer should design so that, initially and throughout life, no absolute maximum value for the intended service is exceeded with any device under the worst probable operating conditions with respect to supply variation, equipment component variation, equipment control adjustment, load variations, signal variation, environmental conditions, and variations in characteristics of the device under consideration and of all other electronic devices in the equipment.

Dimensional drawings are in mm unless otherwise indicated.

VIDICON TUBES

SURVEY VIDICON TUBES

1 inch - magnetic focusing and deflection

All types 95 mA; 6,3 V

type	mesh	photo-conductive layer	quality grade				applications	
			Br	HI	Ind	Med	MS	GP
XQ1031	I	A	●	●	●	●	●	
XQ1032	I	A		●	●	●	●	
XQ1240	S	A	●	●	●	●	●	
XQ1241	S	A		●	●	●	●	
XQ1280	S	B				●		
XQ1285*	S	B				●		

* Fibre-optic faceplate

2/3 inch - magnetic focusing and deflection

XQ1270	I	A	●	●	●			
XQ1271	S	A	●	●	●			

110 mA; 6,3 V

2/3 inch - electrostatic focusing and magnetic deflection

XQ1272	S	A	●	●	●			
XQ1590**	S	A	●	●	●			

** Bi-potential electrostatic focusing lens

1/2 inch - electrostatic focusing and magnetic deflection

XQ1600	S	A	●	●	●			
--------	---	---	---	---	---	--	--	--

107 mA; 2,8 V

Accessories for Vidicon tubes

type	deflection (and focusing) coil unit	sockets
XQ1031, XQ1032 XQ1240, XQ1241 XQ1280, XQ1285	AT1102/01, KV9G AT1116S or equivalent	56098 or equivalent
XQ1270, XQ1271 XQ1272, XQ1590 XQ1600	KV12S or equivalent KV19G or equivalent KV29E or equivalent	56098 or equivalent

Abbreviations used in the tables

I = integral mesh
S = separate mesh
A = standard layer
B = layer with peak response at approx. 475 nm
Br = for black and white and colour broadcast cameras, telecine

HI = for high-quality black and white and colour cameras in sub-broadcast, medical, educational and industrial applications
Ind = for black and white and colour cameras in non-critical industrial applications
Med = in medical or industrial X-ray equipment, coupled with an image intensifier

MS = in cameras for military, surveillance, and scientific applications
GP = general purpose tube for low-cost cameras

GENERAL OPERATIONAL NOTES

1 PROPERTIES OF THE VIDICON PHOTOCONDUCTIVE LAYER

The vidicon photoconductive layer consists mainly of antimony trisulphide (Sb_2S_3). It is built up of a number (2 to 4) of sublayers. Its properties are dependent on the antimony-sulphur ratios and the porosities of the sublayers.

In the vidicons, described in this Data Handbook, two layer variants are found, denominated layer A and layer B. The standard vidicons intended e.g. for industrial and educational applications contain layer A., the vidicons for medical applications in conjunction with X-ray image intensifiers contain layer B.

1.1 Sensitivity

The light transfer characteristic of a vidicon is not linear and depends strongly on the target voltage. A single value for the sensitivity can therefore not be given, but a series of transfer curves is required with e.g. the dark current as a parameter.

For a 1-inch size vidicon with layer A typical light transfer characteristics for three dark current settings are given in Fig. 1.

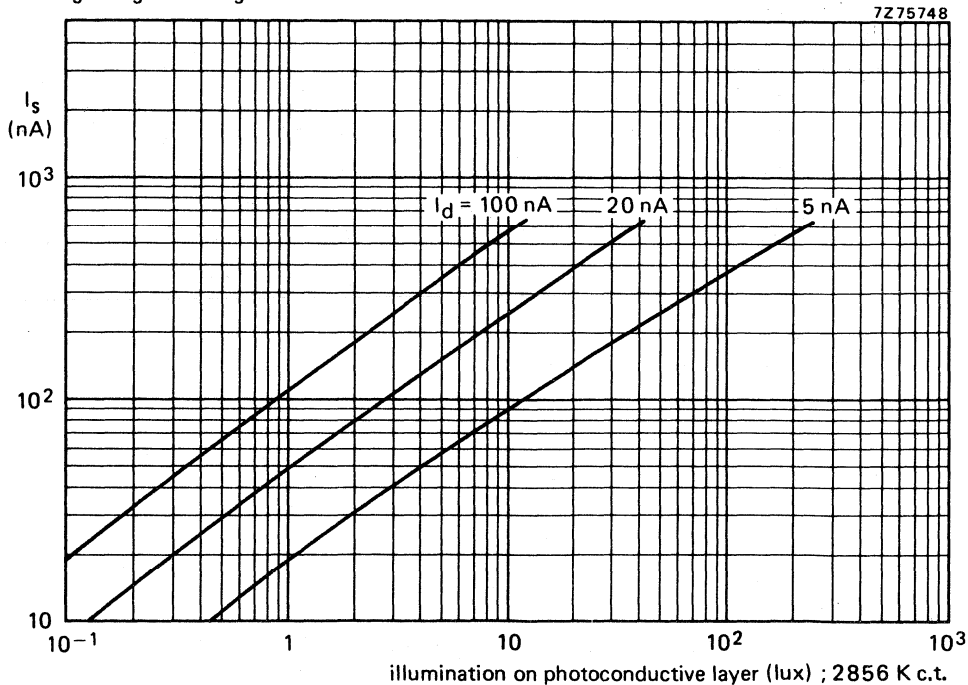

Fig. 1 Typical light transfer characteristics for 1-inch size vidicons with layer A.

(Note: A comparison can be made with Plumbicon tubes: at an input light level on the layer of approx. 8 lx the signal current in nA is equal to the sensitivity in $\mu A/lumen$.)

Vidicons with type B layer are intended mainly for use in X-ray equipment, coupled to an X-ray image intensifier equipped with a P11 or P20 output phosphor. Detailed information on the light transfer characteristics in such situations is found in the data sheets for these tubes: the XQ1280 with plain glass faceplate and the XQ1285 with fibre-optic faceplate.

1.2 Spectral response

Typical relative spectral responses of the layers type A and type B are found in Fig. 2.

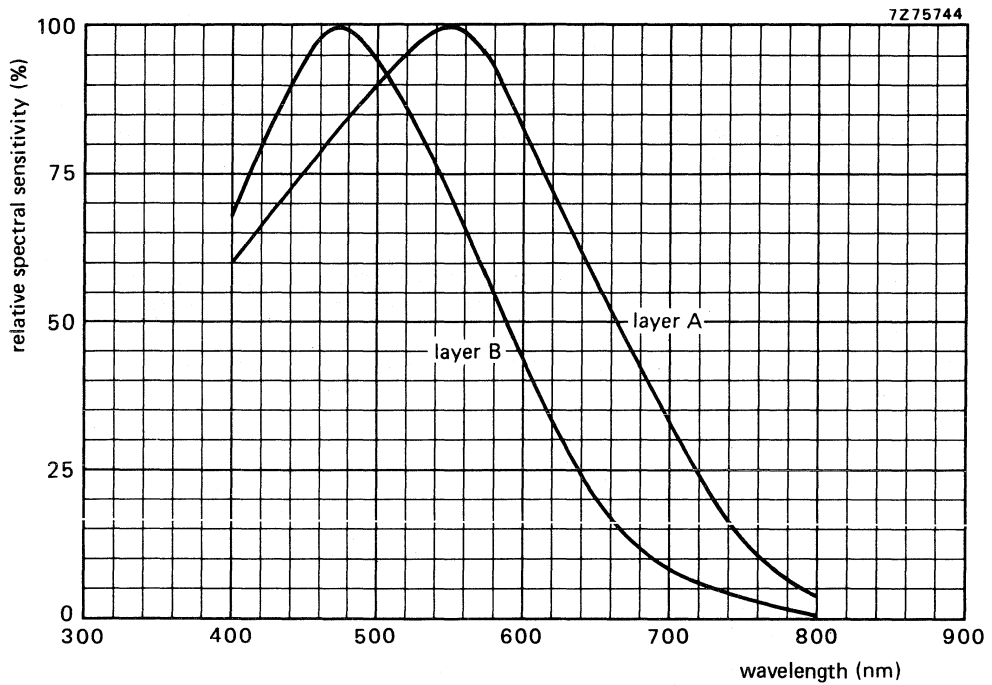

Fig. 2 Typical spectral response curves.

The response has been measured at constant signal output current.

1.3 Dark current

The influence of temperature on dark current for layer type A is shown in Fig. 3. Roughly, the dark current doubles with every 7 to 8 °C temperature increase (this applies also to layer type B).

1.4 Resolution

The photoconductive layer in a vidicon being very thin (2 to 3 μm), gun construction and operating conditions are the determining factors for resolution. As an example, Fig. 4 shows typical modulation transfer characteristics for the 1-inch tube XQ1280 in the low voltage mode and in the high voltage mode (scanning are 9,6 mm x 12,8 mm).

1.5 Lag

Lag is dependent on signal current, dark current and temperature. At low signal currents discharge lag dominates whereas at high signal currents photoconductive lag is preponderant. A typical residual signal level, 200 ms after cessation of an illumination giving a signal current of 200 nA, for the 1-inch vidicon type XQ1240 with layer type A, at a dark current of 20 nA is 8% (16 nA).

2 EQUIPMENT DESIGN AND OPERATING CONDITIONS

(See also General Operational Notes Plumbicon Camera tubes.)

The signal electrode voltage should be limited to such a value that the peak dark current does not exceed 250 nA for tubes with layer A and 100 nA for tubes with layer B.

This is of particular importance for the design and adjustment of vidicon cameras with automatically controlled sensitivity (automatic control of the signal-electrode voltage).

Operation of vidicons at excess dark current may result in damage to the photoconductive target and hence shorten the tube life.

The temperature of the faceplate should never exceed 80 °C, neither during operation nor storage.

Operation at a faceplate temperature of 25 to 30 °C is recommended.

The temperature of the faceplate is determined by the heating effects of the environment, the associated components, the incident illumination and, to a minor extent, by the tube itself.

Under difficult environmental conditions a flow of cooling air directed at the faceplate is recommended. Under conditions of high heat irradiation, an infrared filter between object and camera lens should be used.

A cathode heating time of at least a minute is advised before drawing cathode current. During prolonged idle periods, (days or weeks) gas pressure may very slowly build up in the tube due to residual gas molecules emerging from the electrodes and the glass wall. There is then a slight risk that the pressure is sufficiently high to cause cathode damage by ion bombardment if cathode current is drawn immediately after switching on the camera.

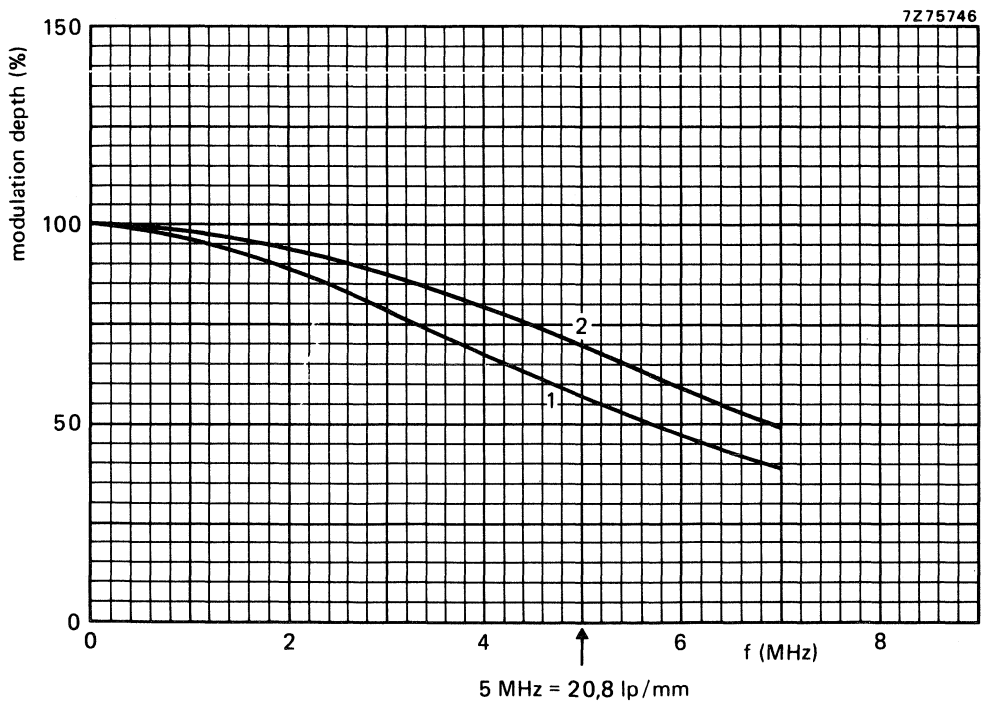
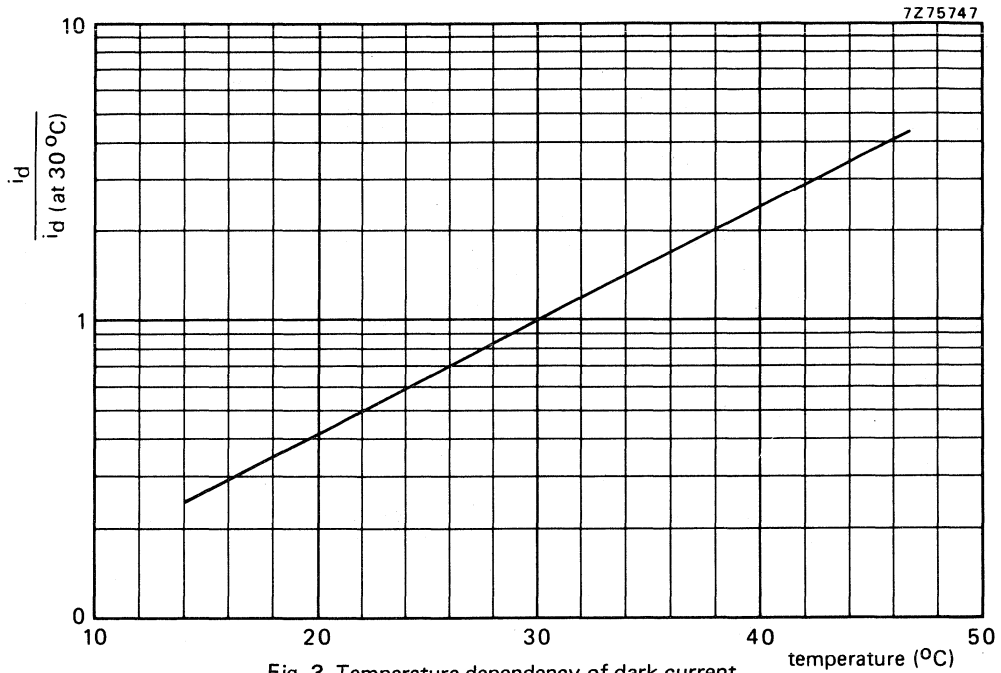

Fig. 4 Typical modulation transfer characteristics for XQ1280.
 Curve 1: $V_{g3} = 375 \text{ V}$, $V_{g4} = 600 \text{ V}$; curve 2: $V_{g3} = 600 \text{ V}$, $V_{g4} = 960 \text{ V}$.

CAMERA TUBES

Vidicon television camera tubes with low heater consumption, integral mesh construction, magnetic focusing, magnetic deflection, short length (130 mm, 5 in), and 25,9 mm (1 in) diameter.

QUICK REFERENCE DATA

Integral mesh	
Focusing	magnetic
Deflection	magnetic
Diameter	25,9 mm (1 in)
Length	130 mm (5 in)
Heater	6,3 V, 95 mA
Limiting resolution	600 TV lines

The electrical and mechanical properties of the two types are essentially identical, the main difference being found in the degree of freedom from blemishes of the photoconductive layers.

XQ1031 — intended for use in industrial and broadcast applications in which a high standard of performance is required.

XQ1032 — general purpose tube for less critical industrial applications, experiments, amateur use etc.

OPTICAL

Diagonal of quality rectangle on photoconductive layer (aspect ratio 3 : 4) 16 mm

Orientation of image on photoconductive layer:

The direction of the horizontal scan should be essentially parallel to the plane passing through the longitudinal tube axis and the short index pin.

Photoconductive layer	type A
Spectral response, max. response at	approx. 550 nm
Faceplate thickness	2,5 mm
refractive index	1,487

HEATING

Indirect by a.c. or d.c.; parallel or series supply

Heater voltage	V_f	6,3 V \pm 10%
Heater current at $V_f = 6,3$ V	I_f	95 mA

When the tube is used in a series heater chain, the heater voltage must not exceed 9,5 V r.m.s. when the supply is switched on.

CAPACITANCES

Signal electrode to all

$$C_{as} \approx 4,6 \text{ pF}$$

This capacitance, which effectively is the output impedance of the tube, increases when the tube is inserted into the deflection and focusing coil unit.

MECHANICAL DATA

Dimensions in mm

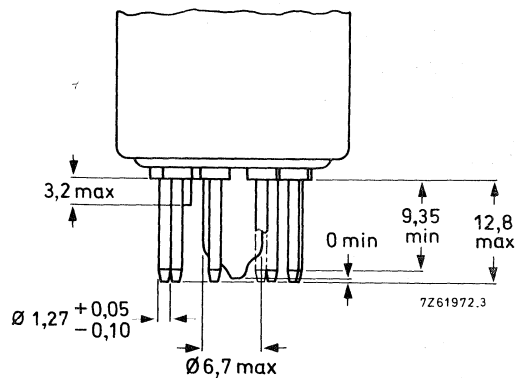
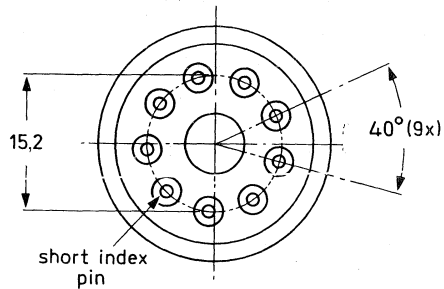
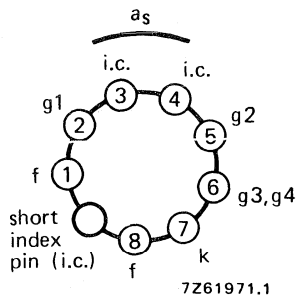
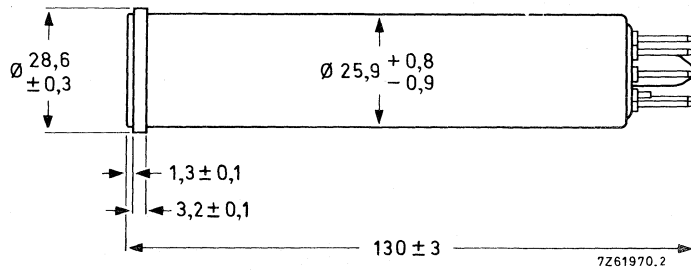

Base: JEDEC no. E8-11

Mounting position: any

Net mass: $\approx 57 \text{ g}$

ACCESSORIES

Socket	type 56602 or equivalent
Deflection and focusing coil unit	AT1102/01, KV9G or equivalent

DEFLECTION magnetic**FOCUSING** magnetic**LIMITING VALUES**

(Absolute maximum rating system) for scanned area of 9,6 mm x 12,8 mm (3/8 in x 1/2 in)

"Full-size scanning", i.e. scanning of a 9,6 mm x 12,8 mm area of the photoconductive layer should always be applied. Underscanning, i.e. scanning of an area less than 9,6 mm x 12,8 mm, may cause permanent damage to the specified full-size area.

Signal-electrode voltage	V_{as}	max.	100 V
Grid 4 voltage and grid 3 voltage	$V_{g4, g3}$	max.	750 V
Grid 2 voltage	V_{g2}	max.	750 V
Grid 1 voltage, negative	$-V_{g1}$	max.	300 V
positive	V_{g1}	max.	0 V
Cathode-to-heater voltage, peak positive	V_{kfp}	max.	125 V
peak negative	$-V_{kfp}$	max.	10 V
Dark current, peak	I_{darkp}	max.	250 nA
Output current, peak	I_{asp}	max.	550 nA *
Faceplate illumination	E	max.	10 000 lx
Faceplate temperature, storage and operation	T	max.	70 °C **
Cathode heating time before drawing cathode current	t_h	min.	1 min

* Video amplifiers should be capable of handling signal-electrode currents of this magnitude without overloading the amplifier or distorting the picture.

** Under difficult environmental conditions a flow of cooling air directed at the faceplate is recommended. When televising flames and furnaces appropriate infrared absorbing filters should be used.

OPERATING CONDITIONS AND PERFORMANCE

notes

For a scanned area of 9,6 mm x 12,8 mm and a faceplate temperature of 25 to 35 °C.

CONDITIONS

Grid 4 and grid 3 (beam focus electrode) voltage	$V_{g4,g3}$	250 to 300 V	1
Grid 2 (accelerator) voltage	V_{g2}	300 V	
Grid 1 voltage for picture cut-off (no blanking applied)	V_{g1}	-100 to -45 V	
Blanking voltage, peak-to-peak			
when applied to grid 1		75 V	
when applied to the cathode		20 V	
Flux density at centre of focusing coil		4,0 mT	
Flux density of adjustable alignment coils		0 to 0,4 mT	

PERFORMANCE

		min.	typ.	max.		
Signal electrode voltage for dark current of 20 nA	V_{as}	10	30	V		
Signal current faceplate illumination 10 lx c.t. 2856 K, dark current 20 nA	I_s	150	240	nA		
Decay: residual signal current 60 ms after cessation of the illumination (c.t. 2856 K, initial signal current 200 nA, dark current 20 nA)			21	%		
Limiting resolution, at picture centre		500	600	TV lines	2	
at picture corners		350	450	TV lines	2	
Average γ of transfer characteristic for signal currents between 20 and 200 nA		0,55	0,74	0,85		
Spurious signals (spot and blemishes)						3

Notes see next page.

NOTES

- Resolution decreases with decreasing grid 3 and 4 voltages. In general grids 3 and 4 should be operated above 250 V.
- On EIA resolution test chart, faceplate illumination adjusted for peak signal current of 200 nA and dark current of 20 nA.
- Conditions:
The camera focused on a uniformly illuminated two-zone test pattern, the diameter of the centre zone (1) being equal to the raster height. Zone (2) being defined as the remainder of the scanned area. Signal electrode voltage adjusted for a dark current of 20 nA, illumination on target (c.t. = 2856 K) adjusted to provide a signal current of 200 nA. Beam current adjusted for correct stabilization.
Scanning amplitudes of the monitor adjusted to obtain a raster with an aspect ratio of 3 : 4.
Monitor set-up and contrast control adjusted for faint raster when lens of camera is capped, and for non-blooming bright raster when lens of camera is uncapped.
Under the above conditions the number and size of the spots visible in the monitor picture will not exceed the limits stated below. Both black and white spots must be counted. Only white and black spots with contrasts $\geq 50\%$ and $\geq 100\%$ respectively (of peak white signal) are taken into account.

XQ1031

Spot size in % of raster height	Maximum number of spots	
	zone 1	zone 2
> 0,8	none	none
$\leq 0,8$ to 0,6	none	none
$\leq 0,6$ to 0,2	1	2
$\leq 0,2$	*	*
total (max.)	2	

XQ1032

Spot size in % of raster height	Maximum number of spots	
	zone 1	zone 2
> 0,8	none	none
$\leq 0,8$ to 0,6	none	1
$\leq 0,6$ to 0,2	2	3
$\leq 0,2$	*	*
total (max.)	4	

- * Do not count spots of this size unless concentration causes a smudgy appearance.
- Minimum separation between any 2 spots greater than 0,4% of raster height is limited to a distance equivalent to 3% of raster height.
 - Tubes are rejected for smudge, lines, streaks, mottled, grainy, or uneven background having contrasts $> 50\%$.

CAMERA TUBES

Vidicon television camera tubes with low heater consumption, separate mesh construction, magnetic focusing, magnetic deflection and 25,9 mm (1 in) diameter intended for use in black-and-white and colour television cameras in industrial, medical and broadcast applications.

QUICK REFERENCE DATA

Separate mesh	
Focusing	magnetic
Deflection	magnetic
Diameter	25,9 mm (1 in)
Length	159 mm (6¼ in)
Heater	6,3 V, 95 mA
Limiting resolution	800 TV lines

The electrical and mechanical properties of the two types are essentially identical, the differences being found in the degree of freedom from blemishes of the photoconductive layers, in the sensitivity and the signal electrode voltage range.

XQ1240 — intended for use in industrial, medical and broadcast applications in which a high standard of performance is required.

XQ1241 — general purpose tube for less critical industrial applications, experiments, amateur use etc.

OPTICAL

Diagonal of quality rectangle on photoconductive layer
(aspect ratio 3 : 4) 16 mm

Orientation of image on photoconductive layer:

The direction of the horizontal scan should be essentially parallel to the plane passing through the short index pin and the longitudinal axis of the tube.

Photoconductive layer	type A
Spectral response, max. response at	approx. 550 nm
Faceplate thickness	2,5 mm
refractive index	1,487

HEATING

Indirect by a.c. or d.c.; parallel or series supply

Heater voltage	V_f	6,3 V \pm 10%
Heater current at $V_f = 6,3$ V	I_f	95 mA

When the tube is used in a series heater chain, the heater voltage must not exceed 9,5 V r.m.s. when the supply is switched on.

XQ1240
XQ1241

CAPACITANCES

Signal electrode to all

$$C_{as} \approx 4,6 \text{ pF}$$

This capacitance, which effectively is the output impedance of the tube, increases when the tube is inserted into the deflection and focusing coil unit.

MECHANICAL DATA

Dimensions in mm

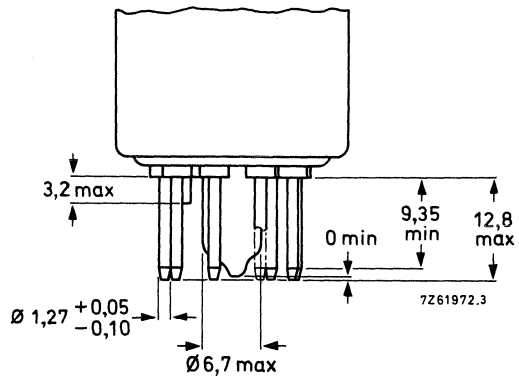
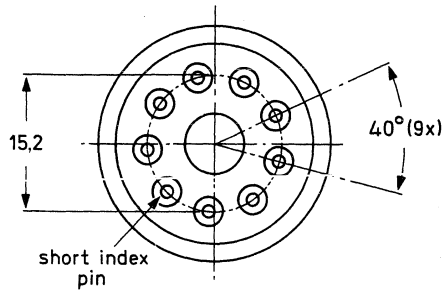
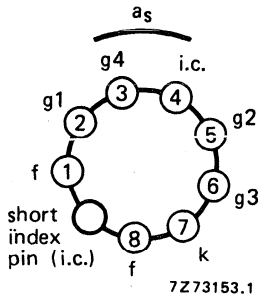
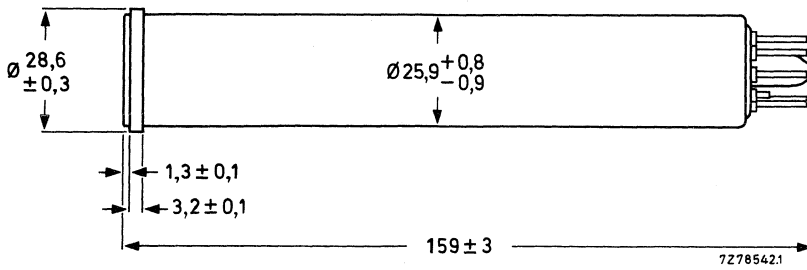

Base: JEDEC no. E8-11

Mounting position: any

Net mass: ≈ 70 g

ACCESSORIES

Socket	type 56602 or equivalent
Deflection and focusing coil unit	AT1102/01, KV9G or equivalent

DEFLECTION magnetic**FOCUSING** magnetic**LIMITING VALUES**

(Absolute maximum rating system) for scanned area of 9,6 mm x 12,8 mm (3/8 in x 1/2 in)

"Full-size scanning", i.e. scanning of a 9,6 mm x 12,8 mm area of the photoconductive layer should always be applied. Underscanning, i.e. scanning of an area less than 9,6 mm x 12,8 mm, may cause permanent damage to the specified full-size area.

Signal-electrode voltage	V_{as}	max.	100 V
Grid 4 voltage	V_{g4}	max.	1000 V
Grid 3 voltage	V_{g3}	max.	1000 V
Grid 2 voltage	V_{g2}	max.	750 V
Grid 1 voltage, negative	$-V_{g1}$	max.	300 V
positive	V_{g1}	max.	0 V
Cathode-to-heater voltage, peak positive	V_{kfp}	max.	125 V
peak negative	$-V_{kfp}$	max.	10 V
Dark current, peak	I_{darkp}	max.	250 nA
Output current, peak	I_{asp}	max.	550 nA*
Faceplate illumination	E	max.	10 000 lx
Faceplate temperature, storage and operation	T	max.	70 °C**
Cathode heating time before drawing cathode current	t_h	min.	1 min

* Video amplifiers should be capable of handling signal-electrode currents of this magnitude without overloading.

** Under difficult environmental conditions a flow of cooling air directed at the faceplate is recommended. When televising flames and furnaces, appropriate infrared absorbing filters should be used.

OPERATING CONDITIONS AND PERFORMANCE

notes

For a scanned area of 9,6 mm x 12,8 mm and a faceplate temperature of 25 to 35 °C.

CONDITIONS

Grid 4 voltage	V_{g4}	500 V	1
Grid 3 (focusing electrode) voltage	V_{g3}	300 V	2
Grid 2 (accelerator) voltage	V_{g2}	300 V	
Grid 1 voltage for picture cut-off (no blanking applied)	V_{g1}	-100 to -45 V	
Blanking voltage, peak-to-peak			
when applied to grid 1		75 V	
when applied to cathode		20 V	
Flux density at centre of focusing coil		3,8 to 4,4 mT	
Flux density of adjustable alignment coils		0 to 0,4 mT	

PERFORMANCE

		min.	typ.	max.	
Signal electrode voltage for dark current of 20 nA					
XQ1240	V_{as}	30	45	60 V	
XQ1241	V_{as}	10	30	V	
Signal current					
faceplate illumination 10 lx, c.t. 2856 K, dark current 20 nA					
XQ1240	I_s	180	300	nA	
XQ1241	I_s	150	240	nA	
Decay: residual signal current					
60 ms after cessation of the illumination (c.t. 2856 K, initial signal current 200 nA, dark current 20 nA)			21	%	
Limiting resolution, at picture centre		650	800	TV lines	3
at picture corners		400	500	TV lines	3
Average γ of transfer characteristic for signal currents between 20 and 200 nA		0,55	0,74	0,85	
Spurious signals (spots and blemishes)					4

Notes see next page.

NOTES

1. Grid 4 voltage must always be higher than grid 3 voltage. The recommended ratio of grid 4 to grid 3 voltage, for best geometry and most uniform signal output depends upon the type of coil used and will be 5 : 3 for the recommended types (see "Accessories").
2. Resolution decreases with decreasing grid 3 voltage. In general grid 3 should be operated above 250 V.
3. On EIA resolution test chart, faceplate illumination adjusted for peak signal current of 200 nA and dark current of 20 nA.
4. Conditions:

The camera focused on a uniformly illuminated two-zone test pattern, the diameter of the centre zone (1) being equal to the raster height. Zone (2) being defined as the remainder of the scanned area. Signal electrode voltage adjusted for a dark current of 20 nA, illumination on the target (c.t. = 2856 K) adjusted to provide a signal current of 200 nA. Beam current adjusted for correct stabilization.

Scanning amplitudes of the monitor adjusted to obtain a raster with an aspect ratio of 3 : 4.

Monitor set-up and contrast control adjusted for faint raster when lens of camera is capped, and for non-blooming bright raster when lens of camera is uncapped.

Black spots having a contrast $\geq 100\%$ ($\geq 10\%$ for XQ1240) and white spots having a contrast $\geq 50\%$ of peak white signal ($\geq 10\%$ for XQ1240) are fully counted.

Under the above conditions the number and size of the spots visible in the monitor picture will not exceed the limits stated below.

XQ1240

Spot size in % of raster height	Maximum number of spots	
	zone 1	zone 2
> 0,8	none	none
$\leq 0,8$ to 0,6	none	none
$\leq 0,6$ to 0,2	1	2
$\leq 0,2$	*	*
total (max.)	2	

XQ1241

Spot size in % of raster height	Maximum number of spots	
	zone 1	zone 2
> 0,8	none	none
$\leq 0,8$ to 0,6	none	1
$\leq 0,6$ to 0,2	2	3
$\leq 0,2$	*	*
total (max.)	4	

* Do not count spots of this size unless concentration causes a smudgy appearance.

- a) Minimum separation between any two spots greater than 0,4% of raster height is limited to a distance equivalent to 3% of raster height.
- b) Tubes are rejected for smudge, lines, streaks, mottled, grainy or uneven background having contrast ratios in excess of 10% (XQ1240) and 50% (XQ1241).

CAMERA TUBE

Small size vidicon television camera tube with low heater consumption, integral mesh construction, magnetic focusing and magnetic deflection. Overall length 108 mm (4¼ in) and diameter 17,7 mm (2/3 in).

The XQ1270 is intended for use in ultra compact TV cameras for industrial and consumer applications.

QUICK REFERENCE DATA

Integral mesh	
Focusing	magnetic
Deflection	magnetic
Diameter	17,7 mm
Length	max. 108 mm
Heater	6,3 V; 110 mA
Limiting resolution	500 TV lines

OPTICAL

Diagonal of quality rectangle on photoconductive layer
(aspect ratio 3 : 4) max. 11 mm

Orientation of image on photoconductive layer:

The direction of the horizontal scan should be essentially parallel to the plane passing through pin 4 and the longitudinal axis of the tube.

Photoconductive layer	type A
Spectral response, max. response at	approx. 550 nm
Faceplate thickness	1,5 mm
refractive index	1,487

HEATING

Indirect by a.c. or d.c.; parallel or series supply

Heater voltage	V_f	6,3 V \pm 10%
Heater current at $V_f = 6,3$ V	I_f	110 mA

When the tube is used in a series heater chain, the heater voltage must not exceed an r.m.s. value of 9,5 V when the supply is switched on.

CAPACITANCES

Signal electrode to all

$$C_{as} \approx 2 \text{ pF}$$

This capacitance, which is effectively the output impedance of the tube, increases when the tube is inserted into the deflection and focusing coil unit.

MECHANICAL DATA

Dimensions in mm

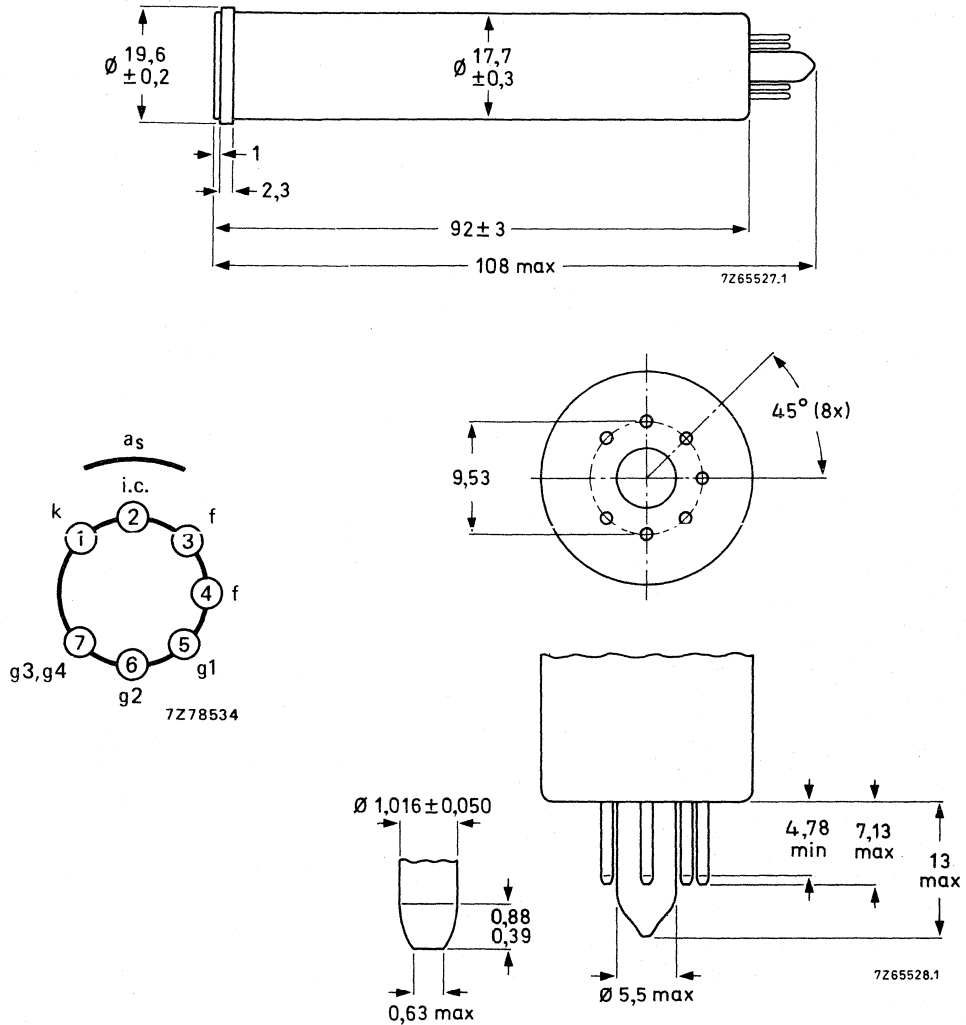

Base: JEDEC no. E7-91.

Mounting position: any

Net mass: $\approx 22 \text{ g}$

ACCESSORIES

Socket	special miniature 7-pin, type 56049 or equivalent
Deflection and focusing coil unit	KV12S or equivalent

DEFLECTION magnetic

FOCUSING magnetic

LIMITING VALUES

(Absolute maximum rating system) for scanned area of 6,6 mm x 8,8 mm.

"Full-size scanning" i.e. scanning of a 6,6 mm x 8,8 mm area of the photoconductive layer should always be applied. Underscanning, i.e. scanning of an area smaller than 6,6 mm x 8,8 mm, may cause permanent damage to the specified full-size area.

Signal electrode voltage	V_{as}	max.	80 V
Grid 4 and grid 3 voltage	$V_{g4,g3}$	max.	750 V
Grid 2 voltage	V_{g2}	max.	350 V
Grid 1 voltage, negative	$-V_{g1}$	max.	300 V
positive	V_{g1}	max.	0 V
Cathode-to-heater voltage, peak positive	V_{kfp}	max.	125 V
peak negative	$-V_{kfp}$	max.	10 V
Dark current, peak	I_{dp}	max.	150 nA
Output current, peak	I_{asp}	max.	500 nA*
Faceplate illumination	E	max.	10 000 lx
Faceplate temperature, storage and operation	T	max.	70 °C**
Cathode heating time before drawing cathode current	t_h	min.	1 min

* Video amplifiers should be capable of handling signal-electrode currents of this magnitude without overloading the amplifier or distorting the picture.

** Under difficult environmental conditions a flow of cooling air directed at the faceplate is recommended. When televising flames and furnaces, appropriate infra-red absorbing filters should be used.

OPERATING CONDITIONS AND PERFORMANCE

For a scanned area of 6,6 mm x 8,8 mm and a faceplate temperature of 25 to 35 °C.

CONDITIONS

			notes
Grid 4 and grid 3 (beam focus electrode) voltage	$V_{g4,g3}$	250 to 300 V	1
Grid 2 (accelerator) voltage	V_{g2}	300 V	
Grid 1 voltage for picture cut-off (no blanking applied)	V_{g1}	-80 to -20 V	
Blanking voltage, peak-to-peak			
when applied to grid 1		75 V	
when applied to the cathode		20 V	
Flux density at centre of focusing coil		5 mT	
Flux density of adjustable alignment magnets		0 to 0,4 mT	

PERFORMANCE

		min.	typ.	max.	
Signal electrode voltage for dark current of 20 nA	V_{as}	10	30	V	
Signal current					
faceplate illumination 10 lx					
c.t. 2856 K, dark current 20 nA	I_s	100	200	nA	
Decay: residual signal current					
60 ms after cessation of the illumination					
(c.t. 2856 K, initial signal current 200 nA, dark current 20 nA)			17	%	
Limiting resolution, at picture centre		400	500	TV lines	2
at picture corners		300	400	TV lines	
Average γ of transfer characteristic for signal currents between 20 and 200 nA (see Fig. 1)		0,55	0,74	0,85	
Spurious signals (spots and blemishes)					3

Notes see next page.

NOTES

- Resolution decreases with decreasing grid 3 and 4 voltages. In general grids 3 and 4 should be operated above 250 V.
- On EIA resolution test chart, faceplate illumination adjusted for peak signal current of 200 nA and dark current of 20 nA.
- Conditions:

The camera focused on a uniformly illuminated two-zone test pattern, the diameter of the centre zone (1) being equal to the raster height. Zone (2) being defined as the remainder of the scanned area. Signal electrode voltage adjusted for a dark current of 20 nA, illumination (c.t. 2856 K) adjusted to provide a signal current of 200 nA. Beam current adjusted for correct stabilization.

Scanning amplitudes of the monitor adjusted to obtain a raster aspect ratio of 3 : 4.

Monitor set-up and contrast control adjusted for faint raster when lens of camera is capped, and for non-blooming bright raster when lens of camera is uncapped.

Under the above conditions the number and size of the spots visible in the monitor picture will not exceed the limits stated below. Both black and white spots must be counted. Only white and black spots with contrasts $\geq 50\%$ and $\geq 100\%$ respectively (of peak white signal) are taken into account.

Spot size in % of raster height	Maximum number of spots	
	zone 1	zone 2
> 0,8	none	none
$\leq 0,8$ to 0,6	none	1
$\leq 0,6$ to 0,2	2	3
$\leq 0,2$	*	*
total (max.)	4	

- * Do not count spots of this size unless concentration causes a smudgy appearance.
- Minimum separation between any 2 spots greater than 0,4% of raster height is limited to a distance equivalent to 3% of raster height.
 - Tubes are rejected for smudge, lines, streaks, mottled, grainy or uneven background having contrasts $> 50\%$.

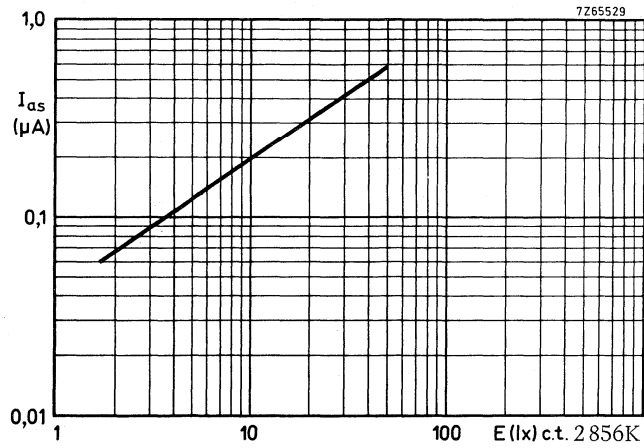

Fig. 1 Typical light transfer characteristic. Scanned area 6,6 mm x 8,8 mm. Faceplate temperature ≈ 30 °C.

CAMERA TUBE

Small size vidicon television camera tube with low heater consumption, separate mesh construction for improved resolution, magnetic focusing and magnetic deflection.

Overall length 108 mm (4¼ in) and diameter 17,7 mm (2/3 in).

The XQ1271 is intended for use in ultra compact TV cameras for industrial and consumer applications.

QUICK REFERENCE DATA

Separate mesh	
Focusing	magnetic
Deflection	magnetic
Diameter	17,7 mm
Length	max. 108 mm
Heater	6,3 V, 95 mA
Limiting resolution	600 TV lines

OPTICAL

Diagonal of quality rectangle on photoconductive layer
(aspect ratio 3 : 4)

11 mm

Orientation of image on photoconductive layer:

The direction of the horizontal scan should be essentially parallel to the plane passing through pin 4 and the longitudinal axis of the tube.

Photoconductive layer

type A

Spectral response, max. response at

approx. 550 nm

Faceplate

thickness

1,5 mm

refractive index

1,487

HEATING

Indirect by a.c. or d.c.; parallel or series supply

Heater voltage

V_f 6,3 V \pm 10%

Heater current at $V_f = 63$ V

I_f 95 mA

When the tube is used in a series heater chain, the heater voltage must not exceed an r.m.s. value of 9,5 V when the supply is switched on.

CAPACITANCES

Signal electrode to all

$$C_{as} \approx 2 \text{ pF}$$

This capacitance, which is effectively the output impedance of the tube, increases when the tube is inserted into the deflection and focusing coil unit.

MECHANICAL DATA

Dimensions in mm

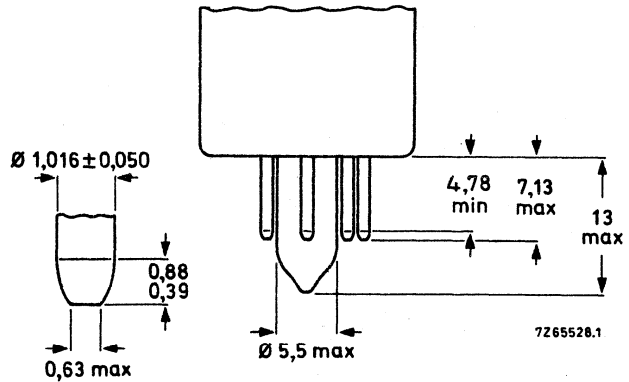
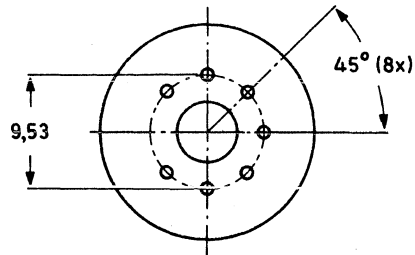
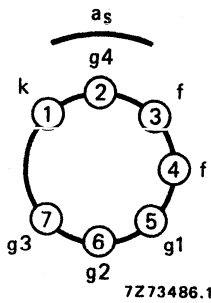
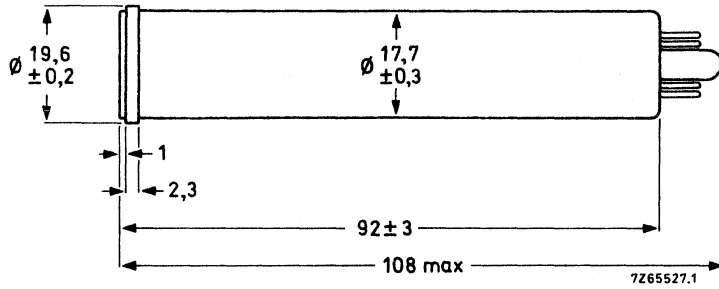

Base: JEDEC no. E7-91

Mounting position: any

Net mass: $\approx 23 \text{ g}$

ACCESSORIES

Socket	special miniature 7-pin, type 56049 or equivalent
Deflection and focusing coil unit	KV12S or equivalent

DEFLECTION magnetic

FOCUSING magnetic

LIMITING VALUES

(Absolute maximum rating system) for scanned area of 6,6 mm x 8,8 mm.

"Full-size scanning" i.e. scanning of a 6,6 mm x 8,8 mm area of the photoconductive layer should always be applied. Underscanning, i.e. scanning of an area smaller than 6,6 mm x 8,8 mm, may cause permanent damage to the specified full-size area.

Signal electrode voltage	V_{as}	max.	80 V
Grid 4 voltage	V_{g4}	max.	750 V
Grid 3 voltage	V_{g3}	max.	750 V
Grid 2 voltage	V_{g2}	max.	350 V
Grid 1 voltage, negative	$-V_{g1}$	max.	300 V
positive	V_{g1}	max.	0 V
Cathode-to-heater voltage, peak positive	V_{kfp}	max.	125 V
peak negative	$-V_{kfp}$	max.	10 V
Dark current, peak	I_{dp}	max.	150 nA
Output current, peak	I_{asp}	max.	500 nA*
Faceplate illumination	E	max.	10 000 lx
Faceplate temperature, storage and operation	T	max.	70 °C**
Cathode heating time before drawing cathode current	t_h	min.	1 min

* Video amplifiers should be capable of handling signal-electrode currents of this magnitude without overloading the amplifier or distorting the picture.

** Under difficult environmental conditions a flow of cooling air directed at the faceplate is recommended. When televising flames and furnaces, appropriate infrared absorbing filters should be used.

OPERATING CONDITIONS AND PERFORMANCE

For a scanned area of 6,6 mm x 8,8 mm and a faceplate temperature of 25 to 35 °C.

CONDITIONS

			notes
Grid 4 voltage	V_{g4}	400 V	1
Grid 3 (beam focus electrode) voltage	V_{g3}	300 V	1,2
Grid 2 (accelerator) voltage	V_{g2}	300 V	
Grid 1 voltage for picture cut-off (no blanking applied)	V_{g1}	-80 to -35 V	
Blanking voltage, peak-to-peak			
when applied to grid 1		75 V	
when applied to the cathode		20 V	
Flux density at centre of focusing coil		5,0 to 5,6 mT	
Flux density of adjustable alignment magnets		0 to 0,4 mT	

PERFORMANCE

		min.	typ.	max.	
Signal electrode voltage for dark current of 20 nA	V_{as}	10	30	V	
Signal current					
faceplate illumination 10 lx					
c.t. 2856 K, dark current 20 nA	I_s	130	200	nA	
Decay: residual signal current					
60 ms after cessation of the illumination					
(c.t. 2856 K, initial signal current 200 nA,					
dark current 20 nA			17	%	
Limiting resolution at picture centre		550	600	TV lines	3
at picture corners		350	450	TV lines	3
Average γ of transfer characteristic for signal currents between 20 and 200 nA (see Fig. 1)		0,55	0,74	0,85	
Spurious signals (spots and blemishes)					4

Notes see next page.

NOTES

1. Grid 4 voltage must always be higher than grid 3 voltage. The recommended ratio of grid 4 voltage to grid 3 voltage both for best geometry and most uniform signal output depends upon the type of coil used and will be 4 : 3 for the recommended type (see "Accessories").
2. Resolution decreases with decreasing grid 3 voltage. In general grid 3 should be operated above 250 V.
3. On EIA resolution test chart; faceplate illumination adjusted for peak signal current of 200 nA and dark current of 20 nA.

4. Conditions:

The camera focused on a uniformly illuminated two-zone test pattern, the diameter of the centre zone (1) being equal to the raster height. Zone (2) being defined as the remainder of the scanned area. Signal electrode voltage adjusted for a dark current of 20 nA, illumination (c.t. 2856 K) adjusted to provide a signal current of 200 nA. Beam current adjusted for correct stabilization.

Scanning amplitudes of the monitor adjusted to obtain a raster aspect ratio of 3 : 4.

Monitor set-up and contrast control adjusted for faint raster when lens of camera is capped, and for non-blooming bright raster when lens of camera is uncapped.

Under the above conditions the number and size of the spots visible in the monitor picture will not exceed the limits stated below. Both black and white spots must be counted. Only white and black spots with contrasts $\geq 50\%$ and $\geq 100\%$ respectively (of peak white signal) are taken into account.

Spot size in % of raster height	Maximum number of spots	
	zone 1	zone 2
> 0,8	none	none
$\leq 0,8$ to 0,6	none	1
$\leq 0,6$ to 0,2	2	3
$\leq 0,2$	*	*
total (max.)	4	

* Do not count spots of this size unless concentration causes a smudgy appearance.

a) Minimum separation between any 2 spots greater than 0,4% of raster height is limited to a distance equivalent to 3% of raster height.

b) Tubes are rejected for smudge, lines, streaks, mottled, grainy or uneven background having contrasts $> 50\%$.

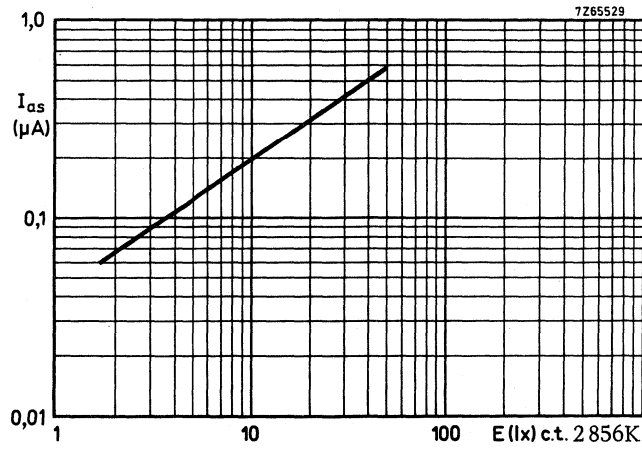

Fig. 1 Typical light transfer characteristic. Scanned area 6,6 mm x 8,8 mm. Faceplate temperature $\approx 30^{\circ}\text{C}$.

CAMERA TUBE

Small size vidicon television camera tube with low heater consumption, separate mesh construction, electrostatic focusing and magnetic deflection. Overall length 108 mm (4¼ in) and diameter 17,7 mm (2/3 in).

The XQ1272 is intended for use in ultra compact TV cameras for industrial and consumer applications in which a minimum of size, weight and power consumption is essential.

QUICK REFERENCE DATA

Separate mesh	
Focusing	electrostatic
Deflection	magnetic
Diameter	17,7 mm
Length	max. 108 mm
Heater	6,3 V, 95 mA
Limiting resolution	550 TV lines

OPTICAL

Diagonal of quality rectangle on photoconductive layer
(aspect ratio 3 : 4) 11 mm

Orientation of image on photoconductive layer:

The direction of the horizontal scan should be essentially parallel to the plane passing through pin 4 and the longitudinal axis of the tube.

Photoconductive layer type A

Spectral response, max. response at approx. 550 nm

Faceplate
thickness 1,5 mm
refractive index 1,487

HEATING

Indirect by a.c. or d.c.; parallel or series supply

Heater voltage V_f 6,3 V \pm 10%

Heater current, at $V_f = 6,3$ V I_f 95 mA

When the tube is used in a series heater chain, the heater voltage must not exceed an r.m.s. value of 9,5 V when the supply is switched on.

CAPACITANCES

Signal electrode to all

$$C_{as} \approx 2 \text{ pF}$$

This capacitance, which is effectively the output impedance of the tube, increases when the tube is inserted into the deflection coil unit.

MECHANICAL DATA

Dimensions in mm

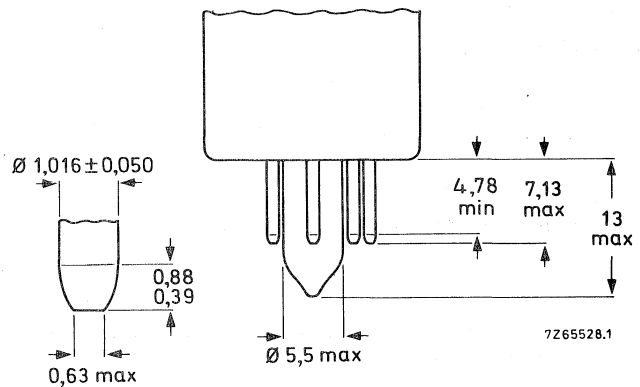
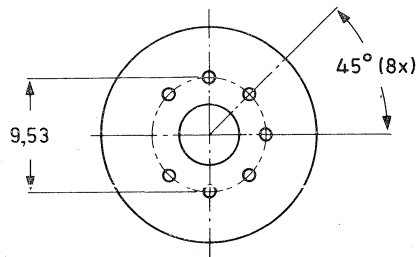
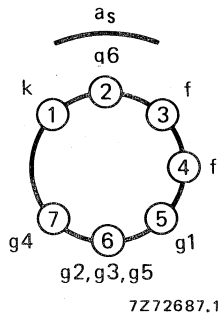
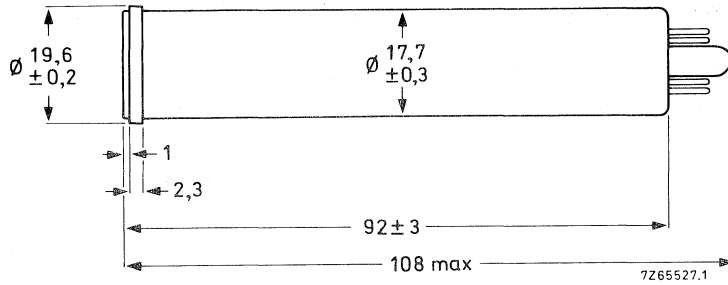

Base: JEDEC no. E7-91

Mounting position: any

Net mass: $\approx 25 \text{ g}$

ACCESSORIES

Socket	special miniature 7-pin, type 56049 or equivalent
Deflection coil unit	KV 19G or equivalent

DEFLECTION magnetic**FOCUSING** electrostatic**LIMITING VALUES**

(Absolute maximum rating system) for scanned area of 6,6 mm x 8,8 mm.

"Full-size scanning" i.e. scanning of a 6,6 mm x 8,8 mm area of the photoconductive layer should always be applied. Underscanning, i.e. scanning of an area smaller than 6,6 mm x 8,8 mm, may cause permanent damage to the specified full-size area.

Signal electrode voltage	V_{as}	max.	80 V
Grid 6 voltage	V_{g6}	max.	600 V
Grid 4 (beam focus electrode) voltage	V_{g4}	max.	350 V
Grid 5, grid 3 and grid 2 voltage	$V_{g5,g3,g2}$	max.	350 V
Grid 1 voltage, negative	$-V_{g1}$	max.	300 V
positive	V_{g1}	max.	0 V
Cathode-to-heater voltage, peak positive	V_{kfp}	max.	125 V
peak negative	$-V_{kfp}$	max.	10 V
Dark current, peak	I_{dp}	max.	150 nA
Output current, peak	I_{asp}	max.	500 nA*
Faceplate illumination	E	max.	10 000 lx
Faceplate temperature, storage and operation	T	max.	70 °C**
Cathode heating time before drawing cathode current	t_h	min.	1 min

* Video amplifiers should be capable of handling signal-electrode currents of this magnitude without overloading the amplifier or distorting the picture.

** Under difficult environmental conditions a flow of cooling air directed at the faceplate is recommended. When televising flames and furnaces, appropriate infrared absorbing filters should be used.

OPERATING CONDITIONS AND PERFORMANCE

For a scanned area of 6,6 mm x 8,8 mm and a faceplate temperature of 25 to 35 °C.

CONDITIONS

			notes
Grid 6 (decelerator) voltage	V_{g6}	500 V	1
Grid 4 (beam focus electrode) voltage	V_{g4}	35 to 55 V	
Grid 5, grid 3 and grid 2 voltage	$V_{g5,g3,g2}$	300 V	1,2
Grid 1 voltage for picture cut-off (no blanking applied)	V_{g1}	-80 to -30 V	
Blanking voltage, peak-to-peak			
when applied to grid 1		75 V	
when applied to the cathode		20 V	
Flux density of adjustable alignment magnets		0 to 0,4 mT	

PERFORMANCE

		min.	typ.	max.	
Signal electrode voltage for dark current of 20 nA	V_{as}	10	30	V	
Signal current					
faceplate illumination 10 lx					
c.t. 2856 K, dark current 20 nA	I_s	130	200	nA	
Decay: residual signal current					
60 ms after cessation of the illumination					
(c.t. 2856 K, initial signal current 200 nA, dark current 20 nA)			17	%	
Limiting resolution at picture centre			600	TV lines	3
at picture corners			450	TV lines	
Average γ of transfer characteristic for signal currents between 20 and 200 nA (see Fig. 1)		0,55	0,74	0,85	
Spurious signals (spots and blemishes)					4

Notes see next page.

NOTES

1. Grid 6 voltage must always be higher than grid 5, 3 and 2 voltages. The recommended voltage ratio of grid 6 to grids 5, 3 and 2 both for best geometry and most uniform signal output current depends upon the type of coil used and will be 5 : 3 for the recommended type (see "Accessories").
2. Grid 5, 3 and 2 voltages must be operated above 250 V to provide sufficient beam current.
3. On EIA resolution test chart, faceplate illumination adjusted for peak signal current of 200 nA and dark current of 20 nA.
4. Conditions:

The camera focused on a uniformly illuminated two-zone test pattern, the diameter of the centre zone (1) being equal to the raster height. Zone (2) being defined as the remainder of the scanned area. Signal electrode voltage adjusted for a dark current of 20 nA, illumination (c.t. 2856 K) adjusted to provide a signal current of 200 nA. Beam current adjusted for correct stabilization.

Scanning amplitudes of the monitor adjusted to obtain a raster aspect ratio of 3 : 4.

Monitor set-up and contrast control adjusted for faint raster when lens of camera is capped, and for non-blooming bright raster when lens of camera is uncapped.

Under the above conditions the number and size of the spots visible in the monitor picture will not exceed the limits stated below. Both black and white spots must be counted. Only white and black spots with contrasts $\geq 50\%$ and $\geq 100\%$ respectively (of peak white signal) are taken into account.

Spot size in % of raster height	Maximum number of spots	
	zone 1	zone 2
> 0,8	none	none
$\leq 0,8$ to 0,6	none	1
$\leq 0,6$ to 0,2	2	3
$\leq 0,2$	*	*
total (max.)	4	

- * Do not count spots of this size unless concentration causes a smudgy appearance.
- a) Minimum separation between any 2 spots greater than 0,4% of raster height is limited to a distance equivalent to 3% of raster height.
 - b) Tubes are rejected for smudge, lines, streaks, mottled, grainy or uneven background having contrasts $> 50\%$.

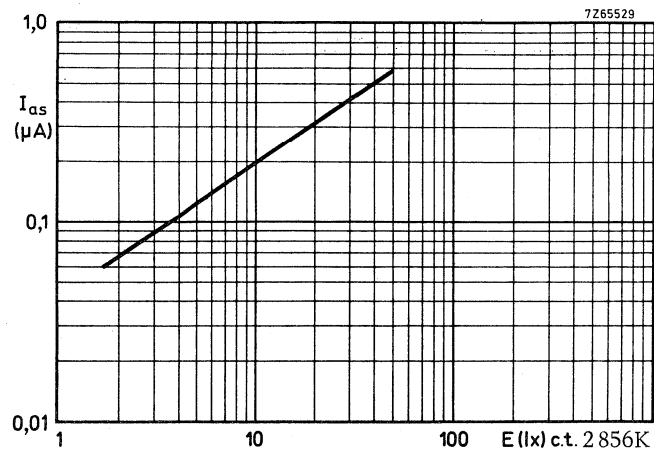

Fig. 1 Typical light transfer characteristic. Scanned area 6,6 mm x 8,8 mm. Faceplate temperature ≈ 30 °C.

CAMERA TUBE

Vidicon TV camera tube with 25,4 mm (1 in) diameter, low heater power consumption, magnetic focusing and deflection, provided with a precision electron gun as in the 1 in diameter Plumbicon® tubes of the XQ1070 series.

The XQ1280 is intended mainly for use in medical or industrial X-ray equipment in which it is lens coupled to an X-ray image intensifier with a P11 or P20 output phosphor.

The tube is provided with a special photoconductive layer of high sensitivity in the 450 to 500 nm spectral region, and medium lag for proper X-ray noise integration.

QUICK REFERENCE DATA

Separate mesh	
Focusing	magnetic
Deflection	magnetic
Diameter	25,4 mm (1 in)
Length	159 mm (6¼ in)
Spectral response, max. at cut-off at	450 to 500 nm approx. 800 nm
Resolution	≥ 60 lp/mm
Heater	6,3 V, 95 mA

OPTICAL DATA

Dimensions of quality area on photoconductive target	circle of 16,2 mm dia (note 1)
Orientation of image on target	
The direction of the horizontal scan should be essentially parallel to the plane defined by pin 1 and the longitudinal axis of the tube.	
Photoconductive layer	type B
Spectral response, max at cut-off at	approx. 475 nm approx. 800 nm
Spectral response curve	see Fig. 1
Faceplate	
Refractive index	n 1,49
Thickness	2,3 ± 0,1 mm

MECHANICAL DATA

Dimensions in mm

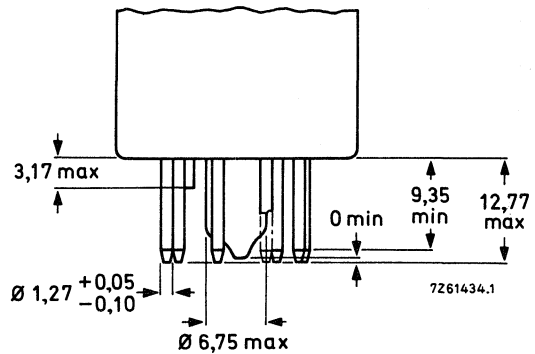
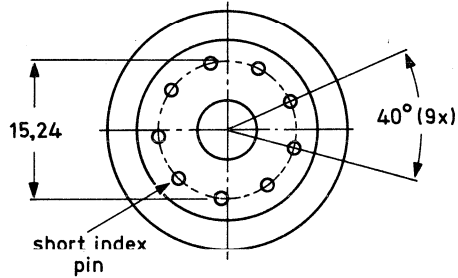
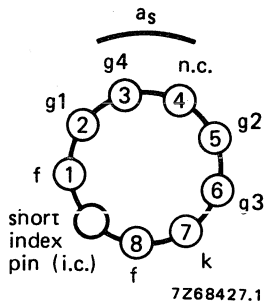
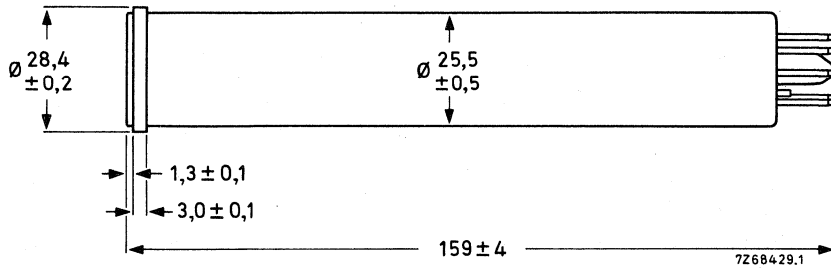

Base: IEC 67-I-33a (JEDEC E8-11)

Mounting position: any

Mass: $\approx 55 \text{ g}$

ACCESSORIES

Socket

Deflection and focusing coil

56602 or equivalent

AT1102/01, AT1116S or equivalent

ELECTRICAL DATA**Heating:** Indirect by a.c. or d.c.; parallel or series supply

Heater voltage	V_f	6,3 V \pm 10%
Heater current	I_f	95 mA

When the tube is used in a series heater chain, the heater voltage must never exceed an r.m.s. value of 9,5 V when the supply is switched on.

Electron gun characteristics

Cut-off		
grid 1 voltage for cut-off at $V_{g2} = 300$ V	V_{g1}	-30 to -100 V
Blanking voltage, peak-to-peak		
on grid 1	V_{g1pp}	50 \pm 10 V
on cathode	V_{kpp}	20 V
Grid 2 current at normally required beam currents	I_{g2}	max. 0,5 mA

Focusing

magnetic

Deflection

magnetic

Capacitance

Signal electrode to all	C_{as}	3 to 5 pF
-------------------------	----------	-----------

This capacitance, which is effectively the output impedance, increases when the tube is inserted in the coil unit.

LIMITING VALUES

(Absolute maximum rating system)

All voltages are referred to the cathode, unless otherwise stated.

Signal electrode voltage	V_{as}	max.	100 V
Grid 4 voltage	V_{g4}	max.	1100 V
Grid 3 voltage	V_{g3}	max.	800 V
Voltage between grid 4 and grid 3	$V_{g4,g3}$	max.	450 V
Grid 2 voltage	V_{g2}	max.	350 V
Grid 1 voltage,			
negative	$-V_{g1}$	max.	125 V
positive	V_{g1}	max.	0 V

Cathode to heater voltage, peak positive	V_{kfp}	max.	125	V	notes
peak negative	$-V_{kfp}$	max.	50	V	
External resistance between cathode and heater at $-V_{kfp} > 10$ V	R_{kf}	min.	2	$k\Omega$	
Dark current, peak	I_{darkp}	max.	0,1	μA	
Output current, peak	I_{asp}	max.	0,6	μA	
The video amplifier should be capable of handling signal electrode currents of this magnitude without overloading.					
Faceplate illumination	E	max.	5000	lx	
Faceplate temperature, storage and operation	T	max.	80	$^{\circ}C$	

OPERATING CONDITIONS AND PERFORMANCE

For a target area of 15 mm diameter; faceplate temperature 30 ± 2 $^{\circ}C$.
All voltages are referred to the cathode, unless otherwise stated.

Typical operating conditions

		normal operation	operation for high resolution		
Grid 1 (control grid) voltage	V_{g1}	adjusted for sufficient beam current to stabilize a peak output current, I_{asp} , of 600 nA			
Grid 2 (accelerator) voltage	V_{g2}	300	300	V	
Grid 3 (collector) voltage	V_{g3}	375	600	V	2
Grid 4 (mesh) voltage	V_{g4}	600	960	V	2
Peak signal current	I_{sp}	150	150	nA	8, 9
Peak dark current	I_{darkp}	20	20	nA	
Blanking voltage, peak-to-peak when applied to grid 1 when applied to cathode	V_{g1pp}	50		V	
	V_{kpp}	20		V	
Field strength at centre of focusing coil (nominal)	H	3600	4800	A/m	3, 4
Field strength of adjustable alignment coils	H	0 to 320	0 to 320	A/m	5
Deflection currents					6

Performance

	min.	typ.	max.		notes
Signal electrode voltage for a peak dark current of 20 nA	V_{as} 30	40	70	V	
Grid 1 voltage for picture cut-off with no blanking applied	V_{g1} -30	-55	-100	V	
Sensitivity					
Illumination required for a peak signal current of 150 nA					
P20	E	1 2×10^{-7}	2 4×10^{-7}	lx W/cm ²	
P11	E	0,2 $1,5 \times 10^{-7}$	0,4 3×10^{-7}	lx W/cm ²	
Decay:					
Residual signal current 200 ms after cessation of the illumination		15	20	%	10
Limiting resolution at picture centre,					
normal operation		≥ 50		lp/mm	11
operation for high resolution		≥ 60		lp/mm	11
Modulation transfer characteristic		see Fig. 4			
Average γ of transfer characteristic for signal currents between 10 nA and 200 nA		0,7			12
Spurious signals		see "Spurious signal specification for XQ1280"			

Notes see next page.

NOTES

1. a. The circular quality area of 16,2 mm diameter is concentric with the faceplate.
b. The scanning amplitudes must be so adjusted that a target area of about 15 mm diameter is displayed on a standard monitor as a circular area with a diameter equal to the raster height. (15 mm x 20 mm scan).
c. The displayed circular area of approximately 15 mm diameter should fall within the quality area of 16,2 mm diameter but is generally not concentric with the latter due to excentricities of the output window of the image intensifier and the optical system.
d. Underscanning of the chosen area, or failure of scanning, should be avoided, since this may cause damage to the photoconductive layer.
2. The optimal grid 4 voltage for best uniformity of black and white level depends on the type of coil unit used and will be 1,5 to 1,6 times V_{g3} for the coil units mentioned under "Accessories". Under no circumstances should grid 4 (mesh) be allowed to operate at a voltage level below that of grid 3, as this may damage the target.
3. Focus current adjusted for optimal electrical focus.
4. The polarity of the focusing coil should be such that its image end attracts an external north-seeking pole.
5. The alignment coil unit should be so positioned that its centre is at a distance of approx. 94 mm (3 11/16 in) from the face of the tube and that its axis coincides with the axis of the tube, the deflecting yoke and the focusing coil.
6. See chapter "Deflection units".
7. The dark current is dependent on the signal electrode voltage and the temperature. This is shown in Figs 2 and 3.
8. Signal current is output current minus dark current.
9. As measured on a waveform oscilloscope.
10. Measured with a 100% peak signal current of 150 nA.
11. Measured with a video amplifier system with suitable bandwidth and a high-quality lens adjusted to f: 5,6.
12. For typical transfer characteristics with P20 and P11 light input see Fig. 5 and 6.

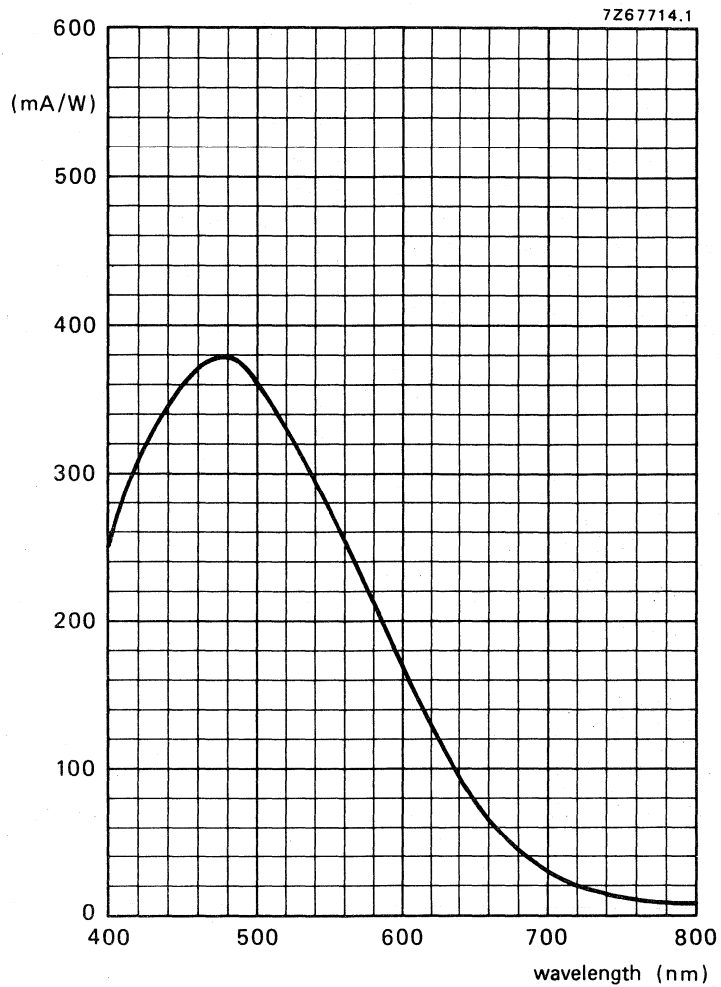

Fig. 1 Typical spectral response curve measured at constant output current $I_{as} = 50$ nA, with $I_{dark} = 20$ nA

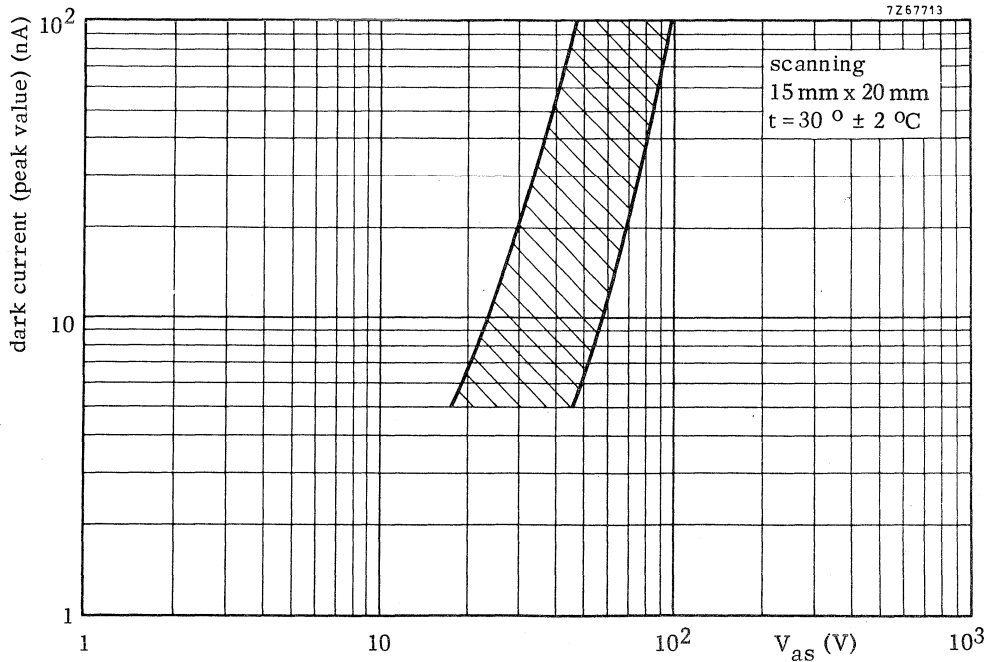

Fig. 2 Dark current range/signal electrode voltage curve.

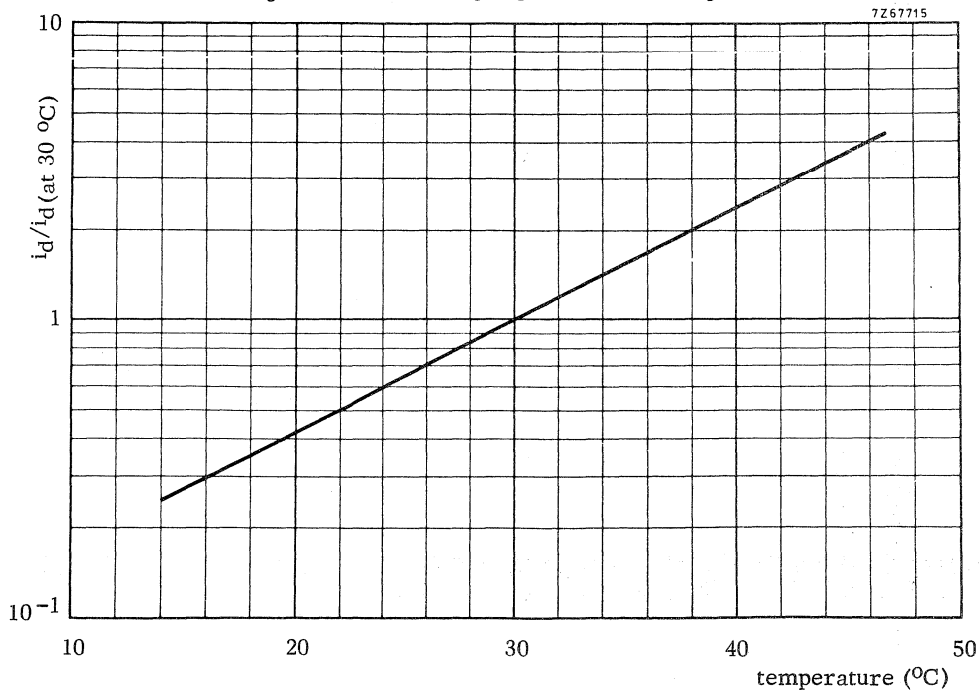

Fig. 3 Temperature dependence of dark current.

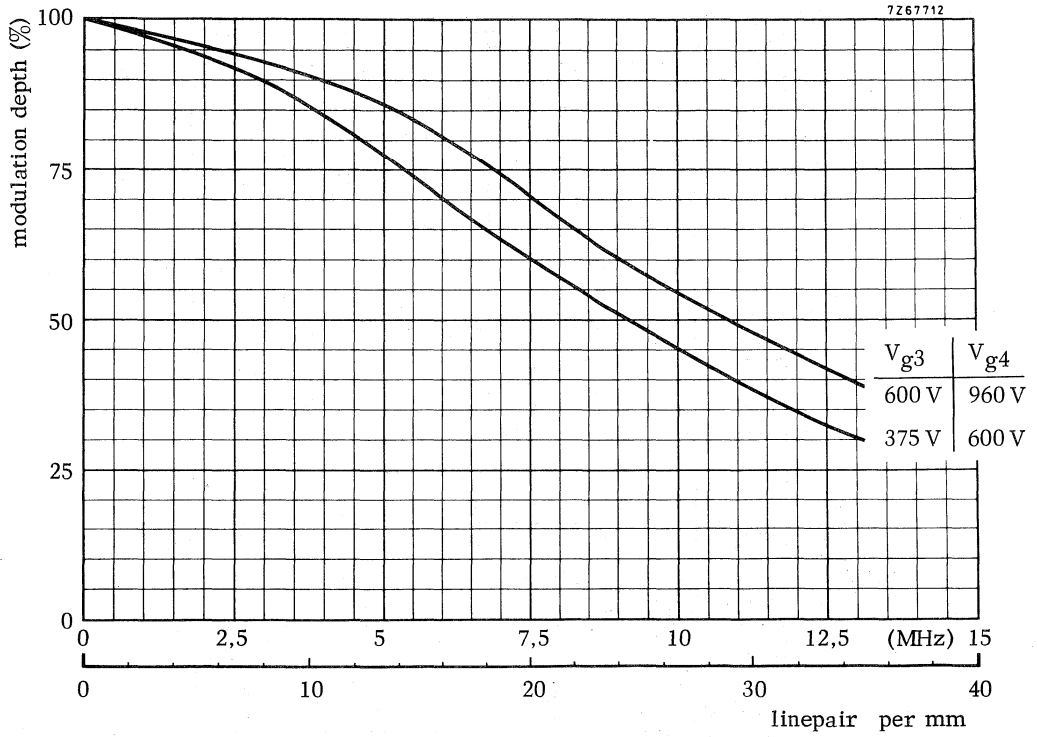

Fig. 4 Squarewave modulation transfer characteristic.

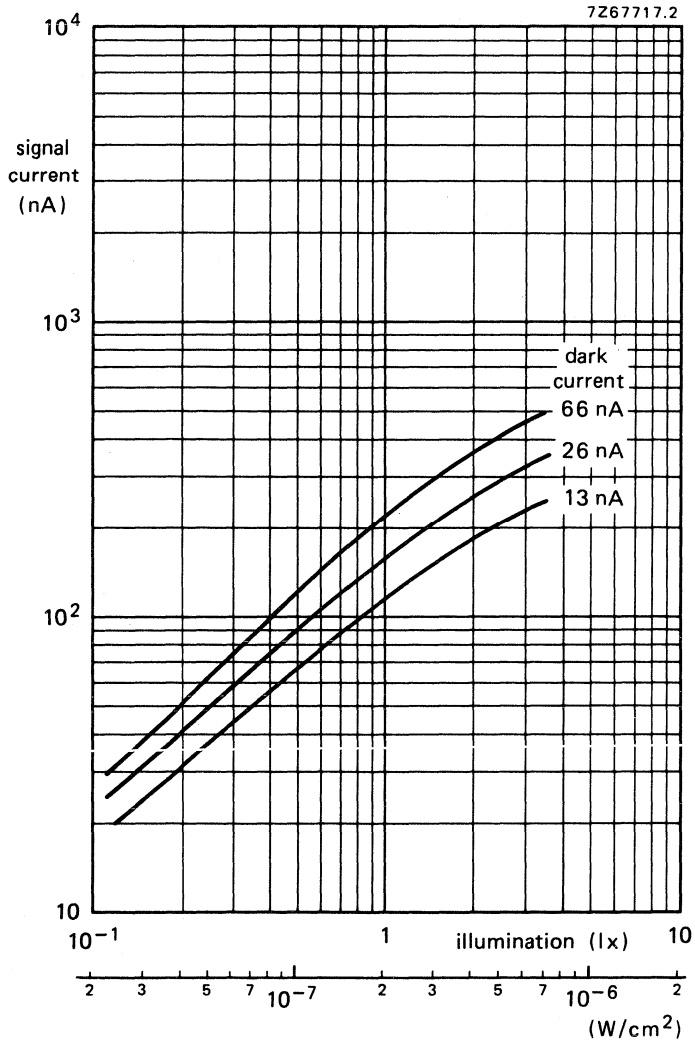

Fig. 5 Typical light transfer characteristic.
 Scanning 15 mm x 20 mm; peak values;
 P20 illumination.

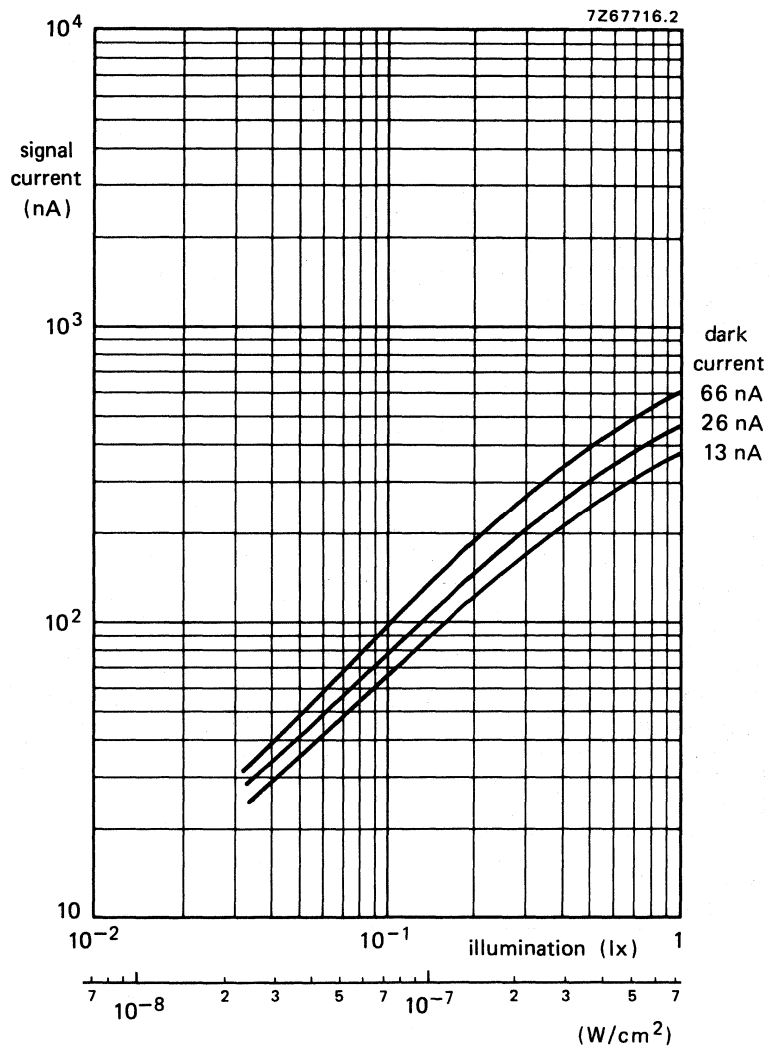
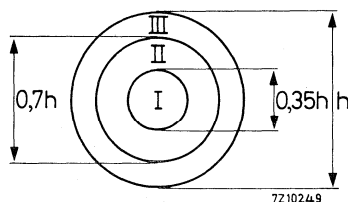

Fig. 6 Typical light transfer characteristic.
Scanning 15 mm x 20 mm; peak values;
P11 illumination.

Spurious signal specification

TEST CONDITIONS

- The tube shall be operated in a test chain under the voltage conditions as shown in the data sheet.
- The scanning amplitudes shall be adjusted to correspond to a scanned area of 16,2 mm x 21,6 mm.
- The tube shall be aligned and focused in accordance with the "Instructions for use".
- A back illuminated test transparency with three quality zones (see Fig. below) is projected onto the specified target area (16,2 mm diameter circular) producing an even illumination.



- The light level shall be adjusted to produce a peak signal current of 150 nA, the beam current shall be adjusted to just stabilize a peak signal current of 600 nA, the signal electrode voltage shall be adjusted for a peak dark current of 20 nA, the temperature of the faceplate shall be 30 ± 2 °C.
- The video amplifier system shall have a bandwidth (-3 dB) of at least 7 MHz.
- The monitor shall be adjusted for a non-blooming white.

Permitted number, size and location of blemishes

Dimensions of blemishes in % of picture height (16,2 mm)	Zone I	Zone II	Zone III
> 0,7	0	0	0
$\leq 0,7$ but > 0,45	0	1	3
$\leq 0,45$ but > 0,2	2	3	6
total	2	6	

Both black and white blemishes as observed on the monitor shall be counted. Blemishes $\leq 0,2\%$ of picture height* and blemishes with a contrast $\leq 6\%$ (of 150 nA peak signal current, as measured on a waveform oscilloscope), however, shall be neglected.

* Spots of this size are allowed unless concentration causes a smudgy appearance. The average contrast of the concentration is taken as the smudge contrast.

CAMERA TUBE

Vidicon TV camera tube with 25,4 mm (1 in) diameter, low heater power consumption, magnetic focusing and deflection, provided with a precision electron gun as in the 1 in diameter Plumbicon® tubes of the XQ1070 series.

The XQ1285 has a fibre optic faceplate and is mainly intended for use in medical or industrial X-ray equipment in which it is directly coupled to an X-ray image intensifier with a P11 or P20 phosphor on a fibre optic output window. For this purpose it is provided with a special photoconductive layer with a high sensitivity in the 450 to 500 nm spectral region and medium lag for proper X-ray noise integration.

QUICK REFERENCE DATA

Faceplate	fibre optic
Separate mesh	
Focusing	magnetic
Deflection	magnetic
Diameter	25,4 mm (1 in)
Length	159 mm (6¼ in)
Heater	6,3 V, 95 mA
Spectral response, max. at cut-off at approx.	450 to 500 nm 800 nm
Resolution	≥ 50 lp/mm

OPTICAL DATA

Dimensions of quality area on photoconductive target	circle of 15,8 mm dia (note 1)
Orientation of image on target	
The direction of the horizontal scan should be essentially parallel to the plane defined by pin 1 and the longitudinal axis of the tube.	
Photoconductive layer	type B
Spectral response, max. at cut-off	approx. 475 nm approx. 800 nm
Spectral response curve	see Fig. 1
Faceplate	
Centre to centre spacing of fibres	7,5 µm
Flat within	1,5 µm
Numerical aperture	1,0

MECHANICAL DATA

Dimensions in mm

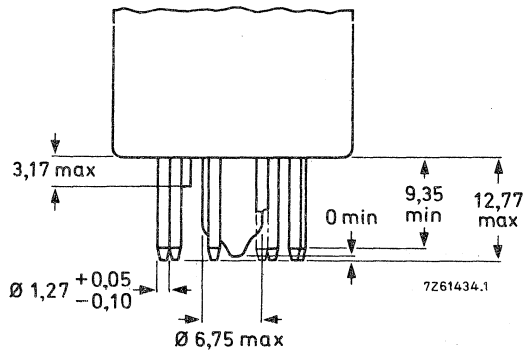
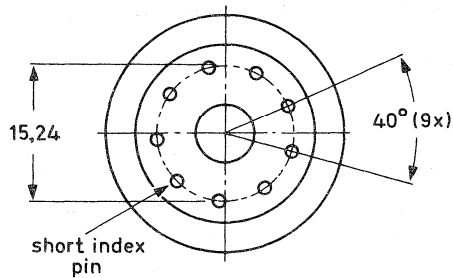
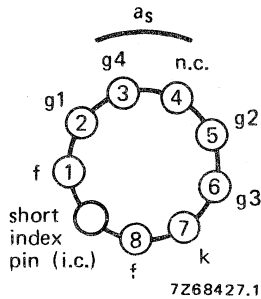
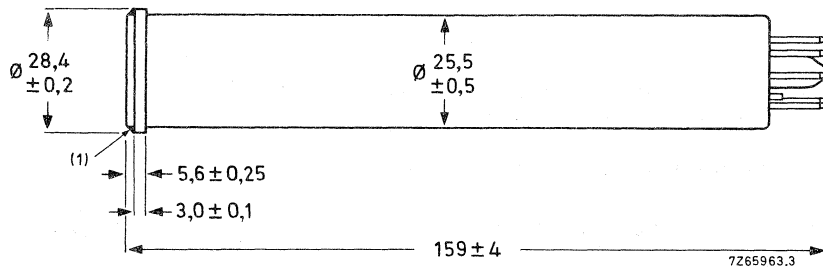

Base: JEDEC E8-11; IEC 67-1-33a

Mounting position: any

Weight: ≈ 55 g

ACCESSORIES

Socket

56602 or equivalent

Deflection and focusing coil unit

AT1102/01, AT1116S or equivalent

(1) Epoxy resin. Proper coupling of the XQ1285 to the fibre optic output window of an image intensifier may be obtained by mechanical arrangements which either exert an evenly distributed axial forward pulling force on the signal-electrode ring or an axial forward pushing force on the base end or socket of the tube.

In either case the recommended force is in the order of 100 to 120 N.

ELECTRICAL DATA**Heating:** Indirect by a.c. or d.c.; parallel or series supply

Heater voltage	V_f	6,3 V \pm 10%
Heater current, at $V_f = 6,3$ V	I_f	95 mA

When the tube is used in a series heater chain, the heater voltage must never exceed an r.m.s. value of 9,5 V when the supply is switched on.

Electron gun characteristics

Cut-off grid 1 voltage for cut-off at $V_{g2} = 300$ V	V_{g1}	-30 to -100 V
Blanking voltage, peak-to-peak on grid 1	V_{g1pp}	50 ± 10 V
on cathode	V_{kpp}	20 V
Grid 2 current at normally required beam currents	I_{g2}	max. 0,5 mA

Focusing

magnetic

Deflection

magnetic

Capacitance

Signal electrode to all	C_{as}	3 to 5 pF
-------------------------	----------	-----------

This capacitance, which effectively is the output impedance of the tube, increases when the tube is inserted into the deflection and focusing coil unit.

LIMITING VALUES

(Absolute maximum rating system)

All voltages are referred to the cathode, unless otherwise stated.

Signal electrode voltage	V_{as}	max.	100 V
Grid 4 voltage	V_{g4}	max.	1100 V
Grid 3 voltage	V_{g3}	max.	800 V
Voltage between grid 4 and grid 3	$V_{g4,g3}$	max.	450 V
Grid 2 voltage	V_{g2}	max.	350 V
Grid 1 voltage, negative	$-V_{g1}$	max.	125 V
positive	V_{g1}	max.	0 V
Cathode-to-heater voltage, peak positive	V_{kfp}	max.	125 V
peak negative	$-V_{kfp}$	max.	50 V
External resistance between cathode and heater at $-V_{kfp} > 10$ V	R_{kf}	min.	2 k Ω

Dark current, peak	I_{darkp}	max.	0,1	μA	notes
Output current, peak	I_{asp}	max.	0,6	μA	
Axial force on signal-electrode ring in forward direction (evenly distributed)		max.	200	N	
Faceplate illumination	E	max.	5000	lx	
Faceplate temperature, storage and operation	T	max.	80	$^{\circ}\text{C}$	
		min.	-30	$^{\circ}\text{C}$	

OPERATING CONDITIONS AND PERFORMANCE

For a target area of 15 mm diameter; faceplate temperature 30 ± 2 $^{\circ}\text{C}$.
All voltages are referred to the cathode, unless otherwise stated.

Typical operating conditions

		normal operation	operation for high resolution		
Grid 1 (control grid) voltage	V_{g1}	adjusted for sufficient beam current to stabilize a peak output current, I_{asp} , of 600 nA			
Grid 2 (accelerator) voltage	V_{g2}	300	300	V	
Grid 3 (collector) voltage	V_{g3}	375	600	V	
Grid 4 (mesh) voltage	V_{g4}	600	960	V	2
Peak signal current	I_{sp}	150	150	nA	8
Peak dark current	i_{darkp}	20	20	nA	
Blanking voltage, peak-to-peak when applied to grid 1	V_{g1pp}	50		V	
	V_{kpp}	50		V	
Field strength at centre of focusing coil (nominal)	H	3200	4800	A/m	3, 4
Field strength of adjustable alignment coils	H	0 to 320	0 to 320	A/m	6
Deflection currents					6

Performance

	min.	typ.	max.		notes
Signal electrode voltage for a peak dark current of 20 nA	V_{as} 30	40	75	V	7, 9
Grid 1 voltage for picture cut-off, with no blanking applied	V_{g1} -30	-55	-100	V	
Sensitivity					
Illumination required for a peak signal current of 150 nA					
P20	E	1,5 3×10^{-7}	3 6×10^{-7}	lx W/cm ²	
P11	E	0,3 $2,3 \times 10^{-7}$	0,6 $4,5 \times 10^{-7}$	lx W/cm ²	
Decay:					
Residual signal current 200 ms after cessation of the illumination		15	20	%	10
Limiting resolution at picture centre,					
normal operation		≥ 50		lp/mm	11
operation for high resolution		≥ 60		lp/mm	11
Modulation transfer characteristic		see Fig. 4			
Average γ of transfer characteristic for signal currents between 10 nA and 300 nA		0,7			12
Spurious signals		see "Spurious signal specification for XQ1285"			

NOTES

1. a. The circular quality area of 15,8 mm diameter is concentric with the faceplate.
b. The scanning amplitudes are so adjusted that a target area of about 15 mm diameter is displayed on a standard monitor as a circular area with a diameter equal to the raster height. (15 mm x 20 mm scan).
c. The displayed circular area of approximately 15 mm diameter should fall within the quality area of 15,8 mm diameter but is generally not concentric with the latter due to eccentricities of the output window of the image intensifier and of the optical system.
d. Underscanning of the chosen target area, or failure of scanning, should be avoided, so as not to cause damage to the photoconductive layer.
2. The optimal grid 4 voltage for best uniformity of black and white level depends on the type of coil unit used and will be 1,5 to 1,6 times V_{g3} for the coil units mentioned under "Accessories". Under no circumstances should grid 4 (mesh) be allowed to operate at a voltage level below that of grid 3, as this may damage the target.
3. Focus current adjusted for optimal electrical focus.
4. The polarity of the focusing coil should be such that its image end attracts an external north-seeking pole.
5. The alignment coil unit should be so positioned that its centre is at a distance of approx. 94 mm (3 11/16 in) from the face of the tube and that its axis coincides with the axis of the tube, the deflecting yoke and the focusing coil.
6. See chapter "Deflection units".
7. The dark current is dependent on the signal electrode voltage and the temperature. This is shown in Figs 2 and 3.
8. Signal current is output current minus dark current.
9. As measured on a waveform oscilloscope.
10. Measured with a 100% peak signal current of 150 nA.
11. Obtained with a video amplifier system with adequate bandwidth.
Measured with a transparent square-wave test pattern applied directly to the faceplate and which is illuminated with P20 light of a lambertian distribution. The average transmission of the test transparency is about 50% of the transmission of the transparency's whites.
No aperture correction or gamma correction is applied.
12. For typical transfer characteristics with P20 and P11 light input see Figs 5 and 6.

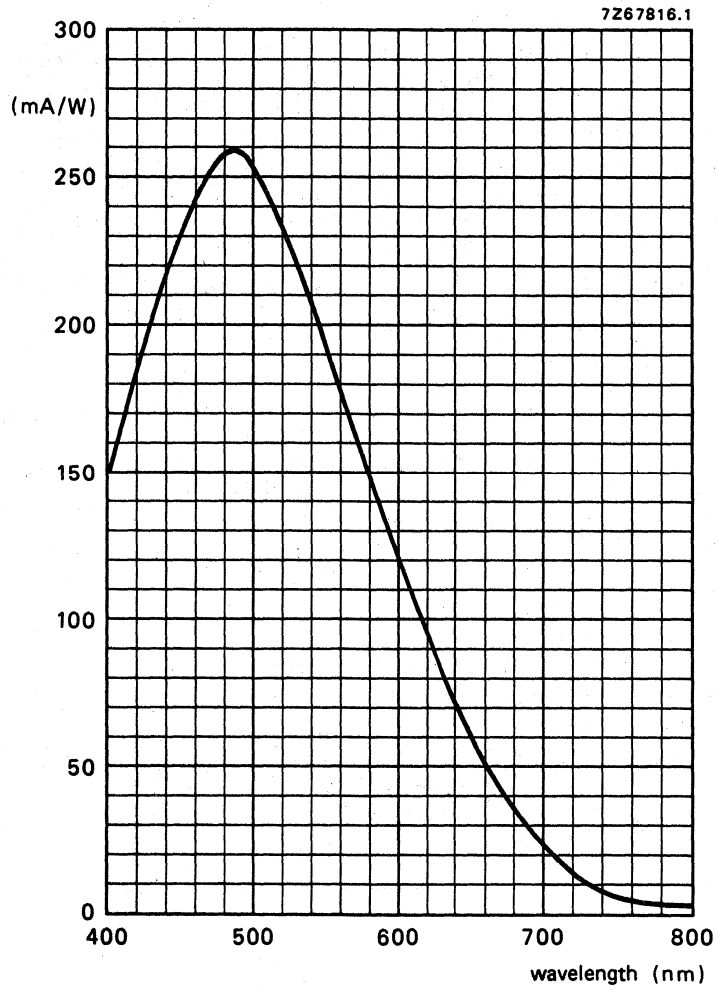

Fig. 1 Spectral response curve.

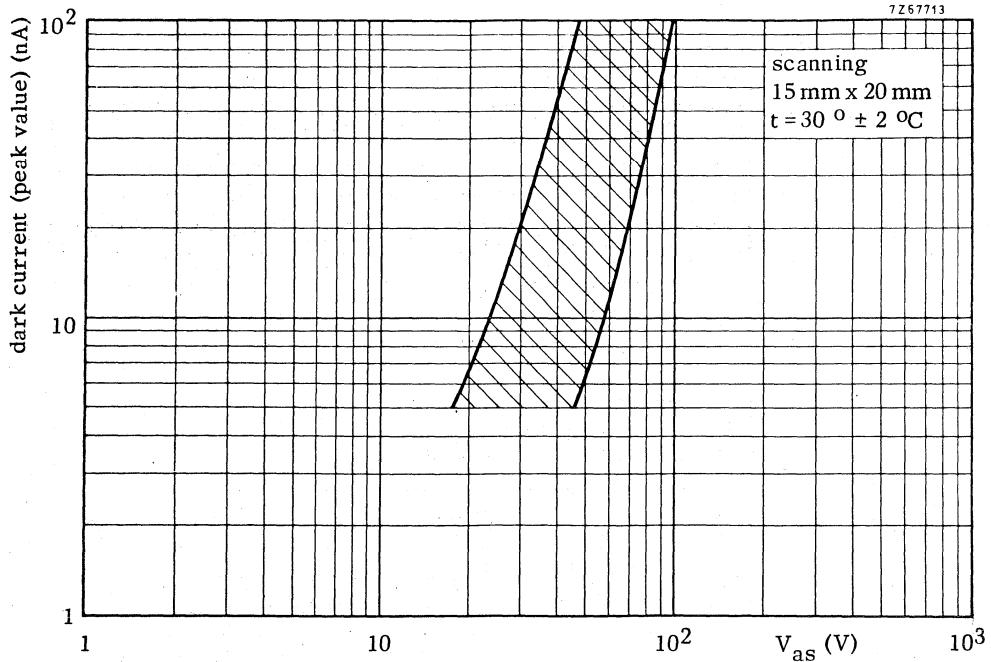

Fig. 2 Dark current range versus signal electrode voltage.

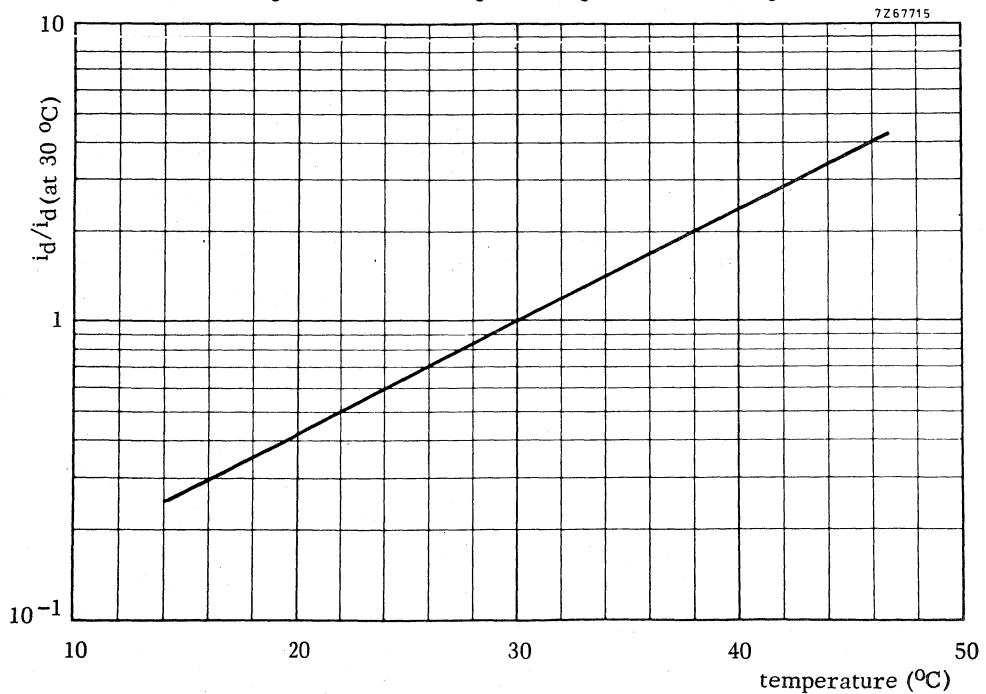

Fig. 3 Temperature dependence of dark current.

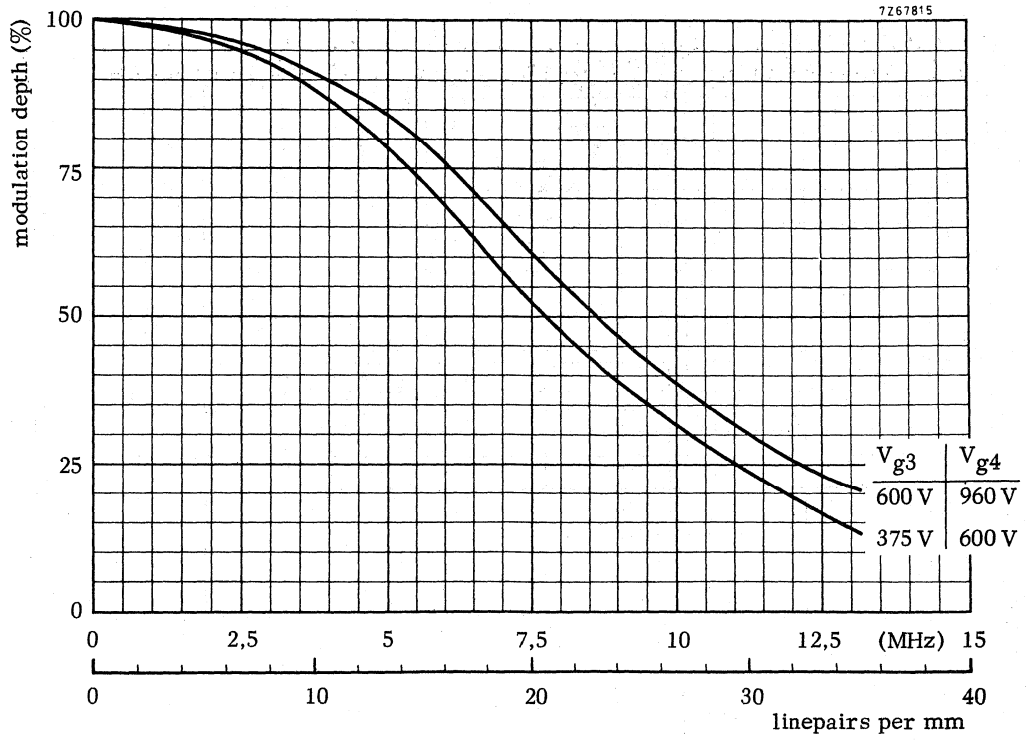

Fig. 4 Square wave modulation transfer characteristic.

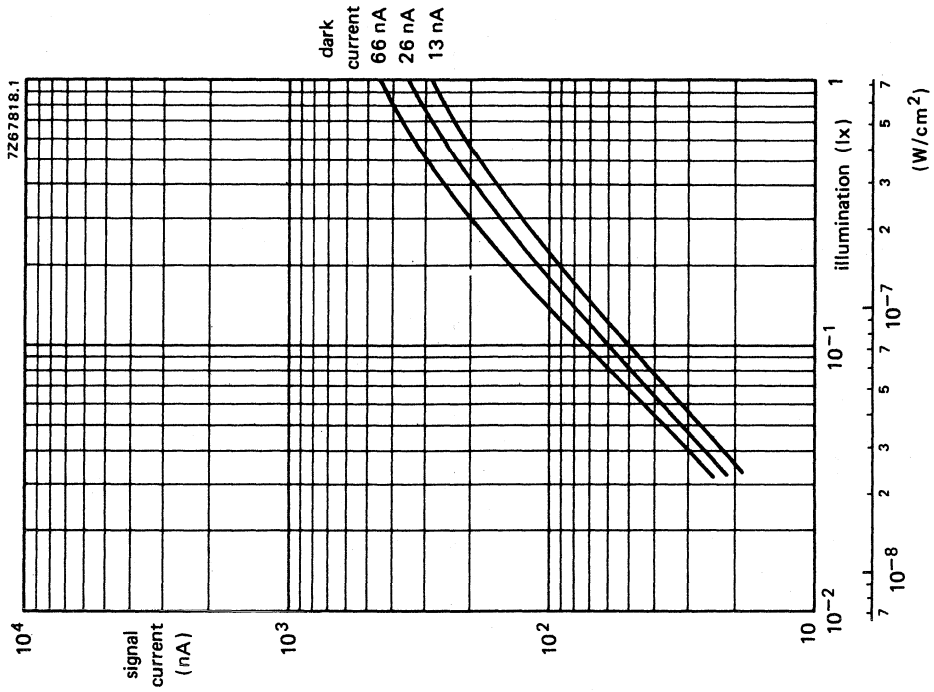

Fig. 6 Typical light transfer characteristics.

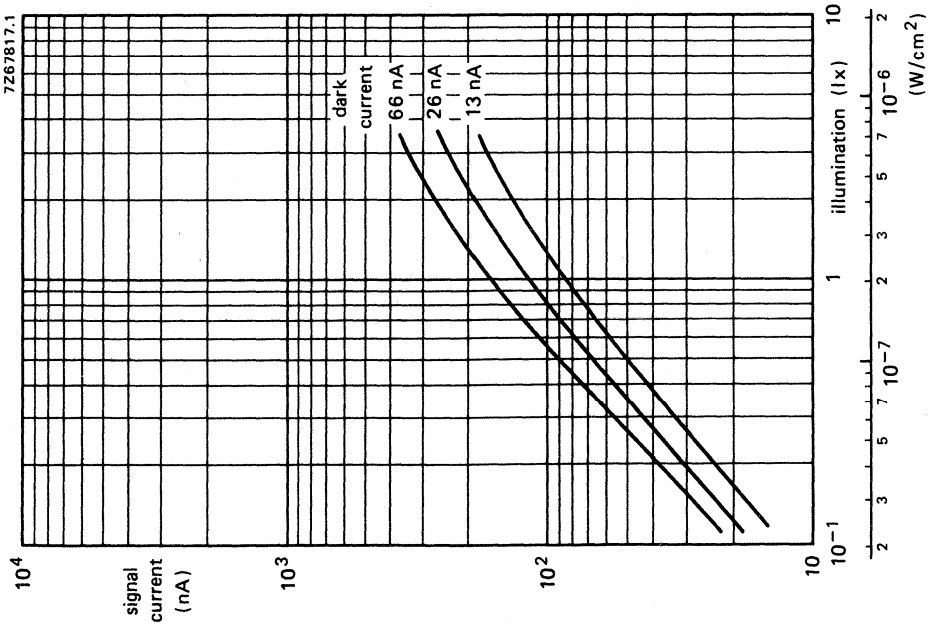
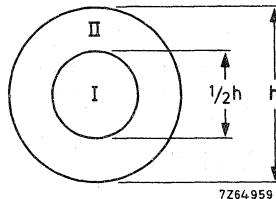

Fig. 5 Typical light transfer characteristics.

Spurious signal specification

TEST CONDITIONS

- The tube shall be operated in a test chain under the voltage conditions as shown in the data sheet.
- The scanning amplitudes shall be adjusted to overscan the target such that it is displayed as a circle on the monitor.
- A test transparency, back illuminated with lambertian light of c.t. = 2856 K, with two quality zones (see Fig. below) is applied directly to the faceplate and positioned such that it is concentric with the target as observed on the monitor.
- The tube shall be aligned and focused.
- The scanning amplitudes shall be slightly reduced, horizontal and vertical centring controls be adjusted such that the circular area of 15,8 mm dia just fits in the picture height of the monitor and is displayed as a circle.
- The temperature of the faceplate shall be 30 ± 2 °C.
The signal electrode voltage shall be adjusted for a peak dark current of 20 nA.
The light level shall be adjusted to produce a peak signal current of 150 nA, the beam current shall be adjusted to just stabilize a peak signal current of 600 nA.
- The video amplifier shall have a bandwidth (-3 dB) of at least 7 MHz.
- The monitor shall be adjusted for a non-blooming white.



$h = 15,8$ mm on target
 $\frac{1}{2}h = 7,9$ mm on target

Permitted number, size and location of blemishes

The table below shows what number of blemishes, black or white, are permitted per size, per zone and total (notes 1 and 2).

Dimensions of blemishes in % of picture height	Zone I		Zone II		Total I + II
	white	black	white	black	
> 0,8	0	0	0	0	0
≤ 0,8 but > 0,5	0	1	0	2	2
≤ 0,5 but > 0,4	1	2	2	3	4
≤ 0,4 but > 0,2	2	3	4	5	6
≤ 0,2 (note 3)					
total	3		6		8

Background structure (e.g. chicken wire pattern) originating from the fibre-optic faceplate shall not have a contrast exceeding 2%. (note 2)

NOTES

- Both black and white blemishes as observed on the monitor shall be counted, however, blemishes ≤ 0,2% of picture height and black blemishes with a contrast ≤ 6%, and white blemishes with a contrast ≤ 3% shall be ignored.
- The contrast is measured as a percentage of 150 nA peak signal current on a waveform oscilloscope. The dimensions of blemishes are determined on the monitor with a transparent blemish gauge, calibrated in percent of picture height.
- If such blemishes form a concentration this will be evaluated as a blemish with as contrast the average contrast of the concentration.

CAMERA TUBE

Small size vidicon television camera tube with low heater consumption, separate mesh construction, electrostatic focusing and magnetic deflection and mechanically interchangeable with vidicons such as XQ1272. Overall length 108 mm (4¼ in) and diameter 17,7 mm (2/3 in).

The XQ1590 is intended for use in ultra compact TV cameras for industrial and consumer applications in which a minimum of size, weight and power consumption is essential.

QUICK REFERENCE DATA

Separate mesh	
Focusing (bipotential focusing lens)	electrostatic
Deflection	magnetic
Diameter	17,7 mm
Length	max. 108 mm
Heater	6,3 V, 95 mA
Limiting resolution	550 TV lines

OPTICAL

Diagonal of quality rectangle on photoconductive layer
(aspect ratio 3 : 4) 11 mm

Orientation of image on photoconductive layer:

The direction of the horizontal scan should be essentially parallel to the plane passing through pin 4 and the longitudinal axis of the tube.

Photoconductive layer		type A
Special response, max. response at	approx.	550 nm
Faceplate		
thickness		1,5 mm
refractive index		1,487

HEATING

Indirect by a.c. or d.c. parallel or series supply

Heater voltage	V_f	6,3 V \pm 10%
Heater current, at $V_f = 6,3$ V	I_f	95 mA

When the tube is used in a series heater chain, the heater voltage must not exceed an r.m.s. value of 9,5 V when the supply is switched on.

CAPACITANCES

Signal electrode to all

$$C_{as} \approx 2 \text{ pF}$$

This capacitance, which is effectively the output impedance of the tube, increases when the tube is inserted into the deflection coil unit.

MECHANICAL DATA

Dimensions in mm

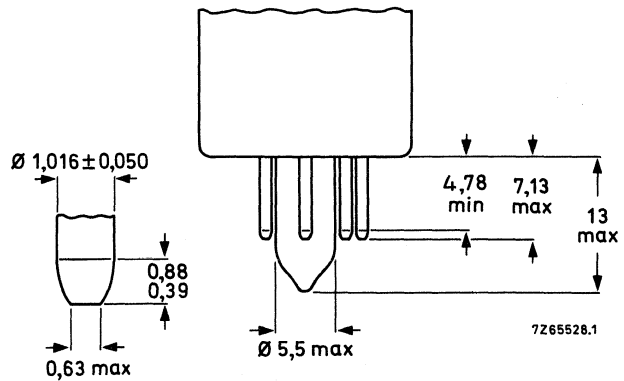
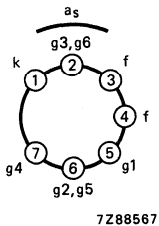
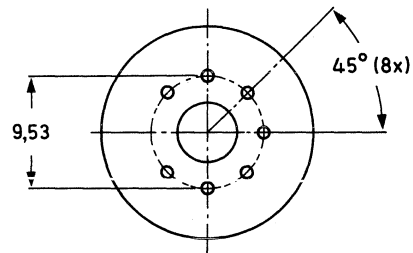
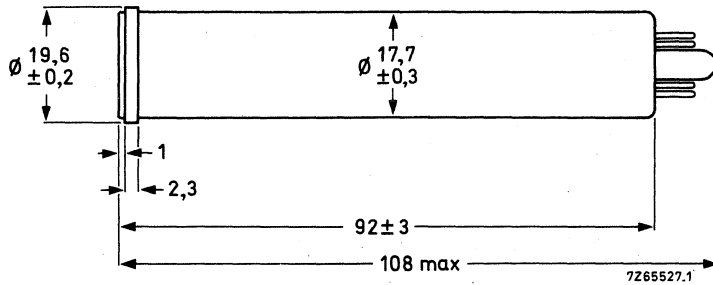

Base: JEDEC no. E7-91

Mounting position: any

Net mass: ≈ 25 g

ACCESSORIES

Socket	special miniature 7-pin, type 56049 or equivalent
Deflection coil unit	KV19G or equivalent

DEFLECTION

magnetic

FOCUSING

electrostatic

LIMITING VALUES

(Absolute maximum rating system) for scanned area of 6,6 mm x 8,8 mm.

"Full-size scanning" i.e. scanning of a 6,6 mm x 8,8 mm area of the photoconductive layer should always be applied. Underscanning, i.e. scanning of an area smaller than 6,6 mm x 8,8 mm, may cause permanent damage to the specified full-size area.

Signal electrode voltage	V_{as}	max.	80 V
Grid 3 and 6 voltage	$V_{g3,g6}$	max.	750 V
Grid 4 (beam focus electrode) voltage	V_{g4}	max.	350 V
Grid 2 and 5 voltage	$V_{g2,g5}$	max.	350 V
Grid 1 voltage, negative	$-V_{g1}$	max.	300 V
positive	V_{g1}	max.	0 V
Cathode-to-heater voltage peak positive	V_{kfp}	max.	125 V
peak negative	$-V_{kfp}$	max.	10 V
Dark current, peak	I_{dp}	max.	150 nA
Output current, peak	I_{asp}	max.	500 nA*
Faceplate illumination	E	max.	10 000 lx
Faceplate temperature, storage and operation	T	max.	70 °C**
Cathode heating time before drawing cathode current	t_h	min.	1 min

* Video amplifiers should be capable of handling signal-electrode currents of this magnitude without overloading the amplifier or distorting the picture.

** Under difficult environmental conditions a flow of cooling air directed at the faceplate is recommended. When televising flames and furnaces, appropriate infrared absorbing filters should be used.

OPERATING CONDITIONS AND PERFORMANCE

For a scanned area of 6,6 mm x 8,8 mm and a faceplate temperature of 25 to 35 °C.

CONDITIONS

			notes
Grid 3 and 6 (decelerator) voltage	$V_{g3,g6}$	500 V	1
Grid 4 (beam focus electrode) voltage	V_{g4}	60 to 85 V	2
Grid 2 and 5 voltage	$V_{g2,g5}$	300 V	3
Grid 1 voltage for picture cut-off (no blanking applied)	V_{g1}	-80 to -30 V	
Blanking voltage, peak-to-peak when applied to grid 1		75 V	
when applied to the cathode		20 V	
Flux density of adjustable alignment magnets		0 to 0,4 mT	

PERFORMANCE

		min.	typ.	max.	
Signal electrode voltage for dark current of 20 nA	V_{as}	15	30	V	
Signal current faceplate illumination 10 lx c.t. 2856 K, dark current 20 nA	I_s	130	200	nA	
Decay: residual signal current 60 ms after cessation of the illumination (c.t. 2858 K, initial signal current 200 nA, dark current 20 nA)			17	%	
Limiting resolution at picture centre			550	TV lines 4	
at picture corners			475	TV lines 4	
Average γ of transfer characteristic for signal currents between 20 and 200 nA (see Fig. 1)		0,55	0,74	0,85	
Spurious signals (spots and blemishes)					5

Notes see next page.

Notes

1. Grids 3 and 6 voltage must always be higher than grids 2 and 5 voltage. The recommended voltage ratio of grids 3 and 6 to grids 2 and 5 both for best geometry and most uniform signal output current depends upon the type of coil used and will be 5 : 3 for the recommended type (see "Accessories").
2. Adjusted for correct electrical focus. This voltage range is higher than that of unipotential electrostatic focus types, such as XQ1272.
3. Grids 2 and 5 voltage must be > 250 V to provide sufficient beam current.
4. On EIA resolution test chart, faceplate illumination adjusted for peak signal current of 200 nA and dark current of 20 nA.
5. Conditions:

The camera focused on a uniformly illuminated two-zone test pattern, the diameter of the centre zone (1) being equal to the raster height. Zone (2) being defined as the remained of the scanned area. Signal electrode voltage adjusted for a dark current of 20 nA, illumination (c.t. 2856K) adjusted to provide a signal current of 200 nA. Beam current adjusted for correct stabilization.

Scanning amplitudes of the monitor adjusted to obtain a raster aspect ratio of 3 : 4.

Monitor set-up and contrast control adjusted for faint raster when lens of camera is capped, and for non-blooming bright raster when lens of camera is uncapped.

Under the above conditions the number and size of the spots visible in the monitor picture will not exceed the limits stated below. Both black and white spots must be counted. Only white and black spots with contrasts $\geq 50\%$ and $\geq 100\%$ respectively (of peak white signal) are taken into account.

Spot size in % of raster height	Maximum number of spots	
	zone 1	zone 2
$> 0,8$	none	none
$\leq 0,8$ to $0,6$	none	1
$\leq 0,6$ to $0,2$	2	3
$\leq 0,2$	*	*
total (max.)	4	

* Do not count spots of this size unless concentration causes a smudgy appearance.

- a) Minimum separation between any 2 spots greater than 0,4% of raster height a limited to a distance equivalent to 3% of raster height.
- b) Tubes are rejected for smudge, lines, streaks, mottled, grainy or uneven background having contrasts $> 50\%$.

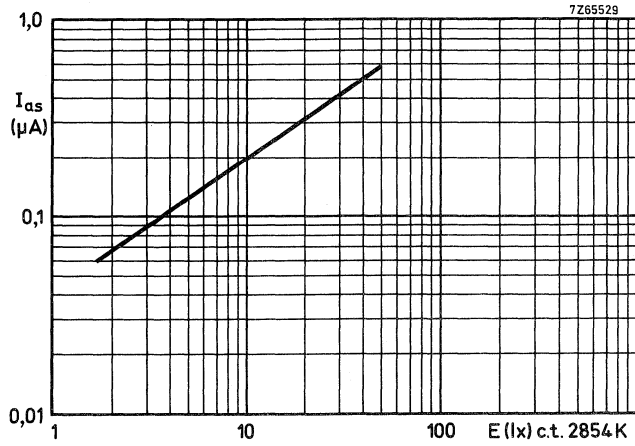

Fig. 1 Typical light transfer characteristic. Scanned area 6,6 mm x 8,8 mm. Faceplate temperature ≈ 30 °C.

CAMERA TUBE

Extremely small size vidicon television camera tube with very low heater consumption, separate mesh construction, electrostatic focusing and magnetic deflection. Overall length 85 mm (3½ in) and diameter 13,5 mm (½ in).

The XQ1600 is intended for use in ultra-compact TV cameras for industrial and consumer applications in which a minimum of size, weight and power consumption is essential.

QUICK REFERENCE DATA

Separate mesh	
Focusing	electrostatic
Deflection	magnetic
Diameter	13,5 mm
Length	max. 85 mm
Heater	2,8 V, 107 mA
Limiting resolution	450 TV lines

OPTICAL

Diagonal of quality rectangle on photoconductive layer
(aspect ratio 3 : 4) 7,75 mm

Orientation of image on photoconductive layer:

The direction of the horizontal scan should be essentially parallel to the plane passing through the short index pin and the longitudinal axis of the tube.

Photoconductive layer		type A
Spectral response, max. response at	approx.	550 nm
Faceplate thickness		1,6 mm
refractive index		1,474

HEATING

Indirect by a.c. or d.c. parallel or series supply

Heater voltage	V_f	$2,8 V \pm 5\%$
Heater current, at $V_f = 2,8 V$	I_f	$107 mA \pm 10\%$

When the tube is used in a series heater chain, the heater voltage must not exceed an r.m.s. value of 3,5 V when the supply is switched on.

CAPACITANCES

Signal electrode to all

$C_{as} \approx 1,5 \text{ pF}$

This capacitance, which is effectively the output impedance of the tube, increases when the tube is inserted into the deflection coil unit.

MECHANICAL DATA

Dimensions in mm

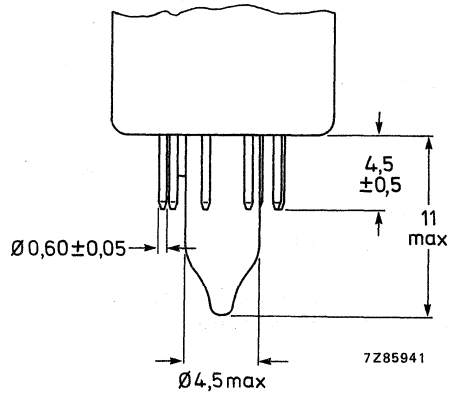
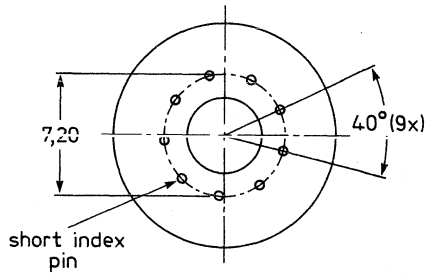
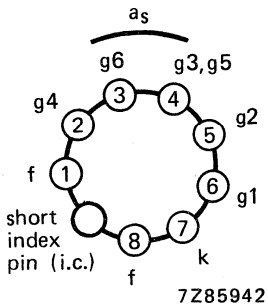
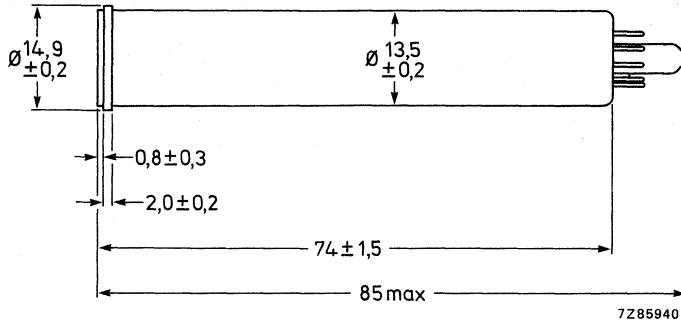

Mounting position: any

Net mass: $\approx 12 \text{ g}$

ACCESSORIES

Socket	special miniature 8-pin type 56600 or equivalent
Deflection coil unit	KV29E or equivalent

DEFLECTION

magnetic

FOCUSING

electrostatic

LIMITING VALUES

(Absolute maximum rating system) for scanned area of 4,65 mm x 6,2 mm.

"Full-size scanning" i.e. scanning of a 4,65 mm x 6,2 mm area of the photoconductive layer should always be applied. Underscanning, i.e. scanning of an area smaller than 4,65 mm x 6,2 mm, may cause permanent damage to the specified full-size area.

Signal electrode voltage	V_{as}	max.	70 V
Grid 6 voltage	V_{g6}	max.	600 V
Grid 4 (beam focus electrode) voltage	V_{g4}	max.	350 V
Grid 3 and 5 voltage	$V_{g3,g5}$	max.	450 V
Grid 2 voltage	V_{g2}	max.	400 V
Grid 1 voltage, negative	$-V_{g1}$	max.	300 V
positive	V_{g1}	max.	0 V
Cathode-to-heater voltage peak positive	V_{kfp}	max.	125 V
peak negative	$-V_{kfp}$	max.	10 V
Dark current, peak	I_{dp}	max.	80 nA
Output current, peak	I_{asp}	max.	500 nA*
Faceplate illumination	E	max.	10 000 lx
Faceplate temperature, storage and operation	T	max.	70 °C**
Cathode heating time before drawing cathode current	t_h	min.	1 min

* Video amplifiers should be capable of handling signal-electrode currents of this magnitude without overloading the amplifier or distorting the picture.

** Under difficult environmental conditions a flow of cooling air directed at the faceplate is recommended. When televising flames and furnaces, appropriate infrared absorbing filters should be used.

OPERATING CONDITIONS AND PERFORMANCE

For a scanned area of 4,65 mm x 6,2 mm and a faceplate temperature of 25 to 35 °C and standard TV scanning rate.

CONDITIONS

			notes
Grid 6 (decelerator) voltage	V_{g6}	500 V	1
Grid 4 (beam focus electrode) voltage	V_{g4}	31 to 55 V	
Grid 3 and 5 voltage	$V_{g3,g5}$	250 V	2
Grid 2 voltage	V_{g2}	300 V	
Grid 1 voltage for picture cut-off (no blanking applied)	V_{g1}	-100 to -40 V	
Blanking voltage, peak-to-peak when applied to grid 1		75 V	
when applied to the cathode		20 V	
Flux density of adjustable alignment magnets		0 to 0,4 mT	

PERFORMANCE

	min.	typ.	max.	
Signal electrode voltage for dark current of 10 nA	V_{as} 10		V	
Signal current faceplate illumination 10 lx c.t. 2856 K, dark current 10 nA	I_s	120	nA	
Decay: residual signal current 60 ms after cessation of the illumination (c.t. 2858 K, initial signal current 100 nA, dark current 10 nA)		20	%	
Limiting resolution at picture centre		480	TV lines	2
Average γ of transfer characteristic for signal currents between 10 and 100 nA (see Fig. 1)	0,55	0,74	0,85	
Spurious signals (spots and blemishes)				3

Notes see next page.

Notes

1. Grid 6 voltage must always be higher than grids 3 + 5 voltage. The recommended voltage ratio of grid 6 to grids 3 + 5 both for best geometry and most uniform signal output current depends upon the type of coil used and will be 2 : 1 for the recommended type (see "Accessories").
2. On EIA resolution test chart, faceplate illumination adjusted for peak signal current of 100 nA and dark current of 10 nA.
3. Conditions:

The camera focused on a uniformly illuminated two-zone test pattern, the diameter of the centre zone (1) being equal to the raster height. Zone (2) being defined as the remainder of the scanned area. Signal electrode voltage adjusted for a dark current of 10 nA, illumination (c.t. 2856K) adjusted to provide a signal current of 100 nA. Beam current adjusted for correct stabilization.

Scanning amplitudes of the monitor adjusted to obtain a raster aspect ratio of 3 : 4.

Monitor set-up and contrast control adjusted for faint raster when lens of camera is capped, and for non-blooming bright raster when lens of camera is uncapped.

Under the above conditions the number and size of the spots visible in the monitor picture will not exceed the limits stated below. Both black and white spots must be counted. Only white and black spots with contrasts $\geq 50\%$ and $\geq 100\%$ respectively (of peak white signal) are taken into account.

Spot size in % of raster height	Maximum number of spots	
	zone 1	zone 2
> 0,8	none	none
$\leq 0,8$ to 0,6	none	1
$\leq 0,6$ to 0,2	2	3
$\leq 0,2$	*	*
total (max.)	4	

* Do not count spots of this size unless concentration causes a smudgy appearance.

a) Minimum separation between any 2 spots greater than 0,4% of raster height a limited to a distance equivalent to 3% of raster height.

b) Tubes are rejected for smudge, lines, streaks, mottled, grainy or uneven background having contrasts $> 50\%$

NEWVICON TUBES

SURVEY NEWVICON[®] TUBES

1 inch - magnetic focusing and deflection

All types 95 mA; 6,3 V

type	mesh	photo conductive layer	quality grade		application
			HI	Ind	
XQ1440	S	Nw	—●—●—●—		
XQ1442*	S	Nw	—●—●—●—		* Fibre-optic faceplate
XQ1443**	S	Nw	—●—●—●—		** Extended near IR response
XQ1444▲	S	Nw	—●—●—●—		▲ Radiation resistant faceplate
XQ1445	S	Nw	—●—●—●—		

2/3 inch - magnetic focusing and deflection

XQ1274	S	Nw	—●—●—●—		
XQ1276**	S	Nw	—●—●—●—		
XQ1380▲	S	Nw	—●—●—●—		

2/3 inch - electrostatic focusing and magnetic deflection

XQ1275	S	Nw	—●—●—●—		
XQ1277▲▲	S	Nw	—●—●—●—		▲▲ Bipotential electrostatic focusing lens
XQ1278▲▲	S	Nw	—●—●—●—		
XQ1381▲	S	Nw	—●—●—●—		▲ Radiation resistant faceplate

½ inch - electrostatic focusing and magnetic deflection

XQ1601	S	Nw	—●—●—●—		107 mA; 2,8 V
XQ1602▲	S	Nw	—●—●—●—		▲ Radiation resistant faceplate

Accessories for Newvicon tubes

type	deflection (and focusing) coil unit	sockets
XQ1440, XQ1442, XQ1443 XQ1444 XQ1445	KV9G AT1116/06S or equivalent	56098 or equivalent
XQ1274, XQ1276, XQ1380 XQ1275, XQ1277, XQ1278 XQ1381	KV12S or equivalent KV19G or equivalent	56098 or equivalent
XQ1601, XQ1602	KV29E or equivalent	56600

Abbreviations used in the tables

S = separate mesh
Nw = cadmium and zinc telluride layer (Newvicon tubes)

HI = for high-quality black and white and colour cameras in sub-broadcast, medical, educational and industrial applications

Ind = for black and white and colour cameras in non-critical industrial applications

MS = in cameras for military, surveillance, and scientific applications

® Newvicon is a registered trade mark for television camera tubes.

GENERAL OPERATIONAL NOTES

1 PROPERTIES OF THE NEWVICON PHOTOCONDUCTIVE LAYER

The Newvicon photoconductive layer is a heterojunction layer, consisting of a sublayer of zinc selenide (ZnSe) and a sublayer formed by a mixture of zinc telluride (ZnTe) and cadmium telluride (CdTe).

In the Newvicon tubes described in this Data Handbook two layer variants are found, differing mainly in spectral response and sensitivity in the infrared region.

1.1 Sensitivity

The Newvicon tube has a high sensitivity in the entire visible spectral region. The sensitivity for white light (colour temperature 2856 K) filtered by an infrared eliminating filter, type B1/K1, is 3 to 4 times as high as that of a Plumbicon® tube.

The light transfer characteristic of the Newvicon tube is linear, except for a slight saturation in the high signal current region.

1.2 Spectral response

Typical spectral responses of the two Newvicon layers are found in Fig. 1.

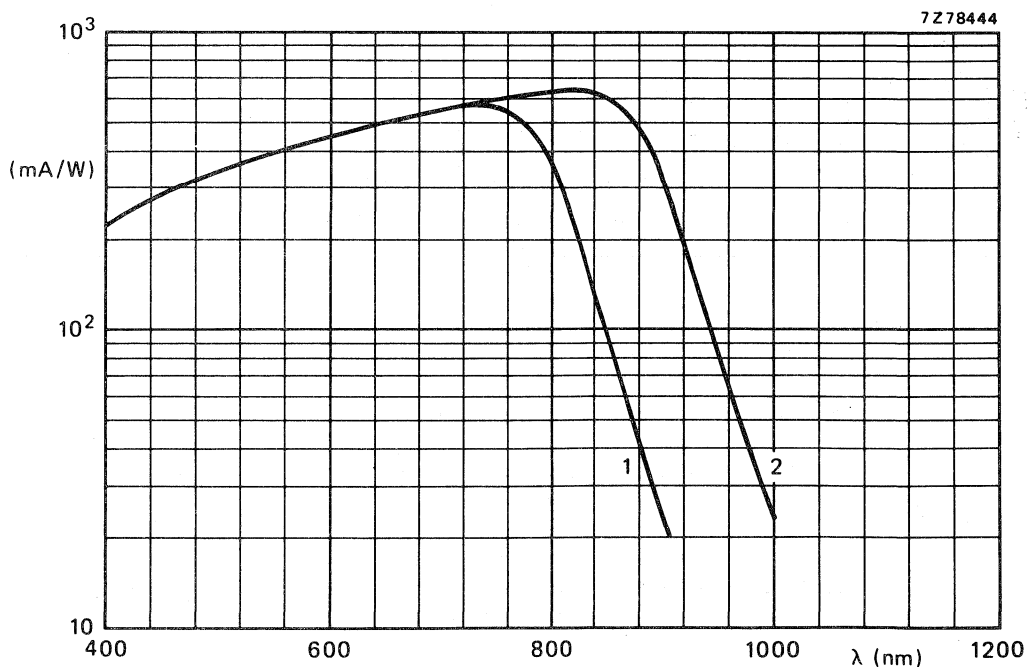

Fig. 1 Typical Newvicon spectral response curves. Curve 1: XQ1274, XQ1275, XQ1278, XQ1380, XQ1381, XQ1440, XQ1442, XQ1444. Curve 2: XQ1276, XQ1277, XQ1443.

® Registered trade mark for television camera tubes.

1.3 Dark current

The dark current in a Newvicon tube is lower than in a vidicon, but it is not negligible. A typical value at 30 °C for a 2/3-inch tube is 5 nA; for a 1-inch tube: 10 nA.

Roughly, the dark current doubles with every 7 to 8 °C temperature increase.

1.4 Resolution

The resolution of a Newvicon tube is determined mainly by the construction of the electron gun and by the operating conditions. Typical modulation transfer characteristics are given in the data sheets.

1.5 Lag

Because of its much larger target capacitance, the lag of a Newvicon tube is significantly higher than that of a Plumbicon tube. As it does not show photoconductive lag like vidicons, however, a Newvicon tube is faster than a vidicon.

Typical values of decay at 200 nA signal current can be found in the data sheets.

1.6 Stray light

The reflectance of the photoconductive layer in a Newvicon tube being low, halation effects in the faceplate of the tube are practically negligible.

1.7 Burn-in

In normal operating conditions, Newvicon tubes show negligible burn-in.

2 EQUIPMENT DESIGN AND OPERATING CONDITIONS

The signal electrode voltage should be adjusted to the value indicated by the tube manufacturer as printed on the envelope ($E_{sj} = \dots V$).

The signal electrode voltage should be adjusted within a tolerance of $\pm 2 V$; the voltage drop across R_I should be kept small. In the case of cathode blanking, the voltage drop across the cathode resistor during read-out should be taken into account. Too low a signal electrode voltage will cause picture sticking effects, whereas too high a voltage may result in picture defects (spots).

A ready way of adjusting the signal electrode voltage, which usually gives satisfactory results, is as follows:

- apply an even illumination to the target, resulting in a signal current of about 150 nA;
- increase the signal electrode voltage until a grainy structure just becomes visible;
- reduce the signal electrode voltage by 5 V, or, alternatively, reduce the signal electrode voltage until slightly above the point where, as observed on an oscilloscope, the signal amplitude commences to decrease.

As Newvicon tubes do not permit sensitivity control by means of regulation of the signal electrode voltage, adequate control is to be achieved by other means (iris control and neutral density filters). If the tube is applied in cameras originally designed for vidicon tubes, the automatic sensitivity control circuitry should be made inoperative and the signal electrode voltage set to the value indicated by the tube manufacturer.

The input light level on the target of a 2/3-inch Newvicon tube should be adjusted at approximately 0,8 lx at the highlight level of the scene. This means that a signal current of 200 nA at highlight level is preferred for optimum operation. For a 1-inch tube the input light level should be set at approximately 0,5 lx.

If the solar image, or a spot image of similar intensity, is focused on the target through a lens opening wider than $f : 11$, instantaneous breakdown of the target will occur. If it is possible that such a situation may arise, protection measures are necessary, e.g. a lens cap, a neutral density filter or a shutter.

The temperature of the faceplate should not exceed 70 °C, neither during operation nor storage. Whilst dark current doubles at every 7 to 8 °C temperature increase, lag decreases and resolution remains practically constant.

CAMERA TUBE

NEWVICON® television camera tube with a photoconductive target composed of cadmium and zinc tellurides featuring high resolution and an extremely high sensitivity.

The XQ1274 is a 2/3 in diameter camera tube with low heater power, separate mesh, magnetic focusing and deflection, and is mechanically interchangeable with vidicons like the XQ1271 and has the same pin connections.

The XQ1274 is intended for use in ultra-compact cameras for security and surveillance applications, for example, where its high sensitivity and resolution, small size and low power consumption are essential.

QUICK REFERENCE DATA

Separate mesh	
Focusing	magnetic
Deflection	magnetic
Diameter	17,7 mm
Length	max. 108 mm
Special response, max. at	approx. 750 nm
cut-off at	approx. 900 nm
Heater	6,3 V, 95 mA
Limiting resolution	650 TV lines

OPTICAL

Diagonal of quality rectangle on photoconductive layer (aspect ratio 3 : 4) 11 mm

Orientation of image on photoconductive layer:

The direction of the horizontal scan should be essentially parallel to the plane passing through the longitudinal tube axis and pin 4.

Spectral response, curve see Fig. 1

Faceplate

thickness 1,5 mm
refractive index 1,61

HEATING Indirect by a.c. or d.c.; parallel or series supply

Heater voltage V_f 6,3 V \pm 10%

Heater current, at $V_f = 6,3$ V I_f 95 mA

When the tube is used in a series heater chain, the heater voltage must not exceed an r.m.s. value of 9,5 V when the supply is switched on.

CAPACITANCES

Signal electrode to all

$$C_{as} \approx 2 \text{ pF}$$

This capacitance, which is effectively the output impedance of the tube, increases when the tube is inserted into the deflection and focusing coil unit.

MECHANICAL DATA

Dimensions in mm

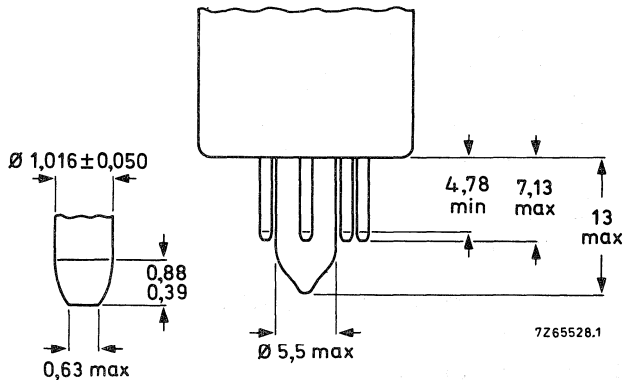
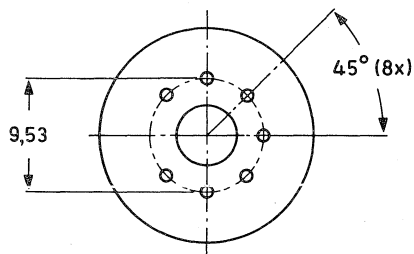
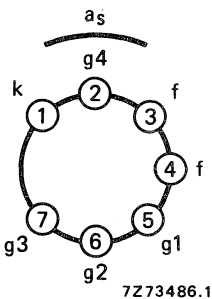
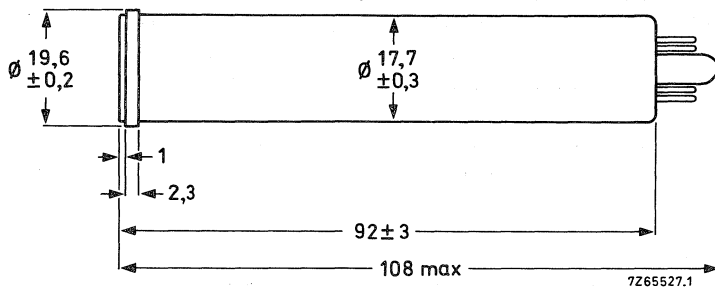

Mounting position: any

Net mass: $\approx 23 \text{ g}$

Base: JEDEC no. E7-91

ACCESSORIES

Socket	special miniature 7-pin, type 56049 or equivalent
Deflection and focusing coil unit	KV12S or equivalent

DEFLECTION

magnetic

FOCUSING

magnetic

LIMITING VALUES (Absolute maximum rating system)

for a scanned area of 6,6 mm x 8,8 mm.

"Full-size scanning" i.e. scanning of a 6,6 mm x 8,8 mm area of the photoconductive layer should always be applied. Underscanning, i.e. scanning of an area smaller than 6,6 mm x 8,8 mm, may cause permanent damage to the specified full-size area.

Signal electrode voltage	V_{as}	max.	50 V *
Grid 4 voltage	V_{g4}	max.	750 V
Grid 3 voltage	V_{g3}	max.	750 V
Grid 2 voltage	V_{g2}	max.	350 V
Grid 1 voltage, negative	$-V_{g1}$	max.	300 V
positive	V_{g1}	max.	0 V
Cathode-to-heater voltage, peak positive	V_{kfp}	max.	125 V
peak negative	$-V_{kfp}$	max.	10 V
Output current, peak	I_{asp}	max.	800 nA**
Faceplate illumination	E	max.	10 000 lx ▲
Faceplate temperature, storage and operation	T	max.	70 °C
Cathode heating time before drawing cathode current	t_h	min.	1 min

* Newwicon tubes do not permit automatic sensitivity control by means of regulation of the signal electrode voltage. Adequate control is therefore to be achieved by other means (iris control and neutral density filters). If the tube is applied in cameras originally designed for vidicon tubes, the automatic sensitivity control circuitry should be made inoperative and the signal electrode voltage set to the value indicated by the tube manufacturer, see also General Operational Notes.

** Video amplifiers should be capable of handling signal-electrode currents of this magnitude without overloading the amplifier or distorting the picture.

▲ White light, uniformly diffused over entire tube face.

Care must be taken not to focus the solar image on the target through a lens opening wider than $f : 11$ to avoid instantaneous breakdown.

OPERATING CONDITIONS AND PERFORMANCE

for a scanned area of 6,6 mm x 8,8 mm, a faceplate temperature of 25 to 35 °C and standard TV scanning rate

Conditions

			notes
Signal electrode voltage	V_{as}	10 to 35 V	1
Grid 4 (decelerator) voltage	V_{g4}	400 V	2
Grid 3 (beam focus electrode) voltage	V_{g3}	300 V	3
Grid 2 (accelerator) voltage	V_{g2}	300 V	
Grid 1 voltage for picture cut-off (no blanking applied)	V_{g1}	-80 to -35 V	
Blanking voltage, peak to peak			
when applied to grid 1		75 V	
when applied to cathode		20 V	
Flux density at centre of focusing coil		5,0 to 5,6 mT	
Flux density of adjustable alignment coils or magnets		0 to 0,4 mT	

Performance

		min.	typ.	max.	
Dark current (at 25 °C)			2	4	nA
Signal current, white light faceplate illumination 1 lx c.t. 2856 K	I_s	200	260		nA
Decay: residual signal current 60 ms after cessation of the illumination initial signal current 200 nA			8	13 %	
Limiting resolution, at picture centre		550	650		TV lines 4
at picture corners		350	450		TV lines 4
Average γ of transfer characteristic, see Fig. 2			≈ 1		
Spurious signals (spots and blemishes)					5

Notes

1. The signal electrode voltage should be adjusted to the value indicated by the tube manufacturer as printed on the envelope ($E_{s1} = \dots V$). To minimize picture sticking effects the signal electrode should be adjusted within a tolerance of $\pm 2 V$; the voltage drop across R_1 should be kept small. In case of cathode blanking the voltage drop across the cathode resistor during read-out should be taken into account.
2. Grid 4 voltage must always be higher than grid 3 voltage. The recommended ratio of grid 4 voltage to grid 3 voltage both for best geometry and most uniform signal output depends upon the type of coil unit used and will be 4 : 3 for the recommended type (see 'Accessories').
3. Resolution decreases with decreasing grid 3 voltage. In general grid 3 should be operated above 250 V.
4. On EIA resolution test chart; faceplate illumination adjusted for a peak output current of 200 nA.

5. Conditions

The camera focused on a uniformly illuminated two-zone test pattern, the diameter of the centre zone (1) being equal to the raster height. Zone (2) being defined as the remainder of the scanned area.

Faceplate illumination adjusted to produce 200 nA signal current, beam current adjusted for correct stabilization.

Monitor set-up and contrast control adjusted for faint raster when lens of camera is capped and for non-blooming bright raster when lens of camera is uncapped.

Under above conditions the number and size of spots per zone visible in the monitor picture will not exceed the limits stated below. Both black and white spots must be counted, unless their contrast is less than 50% of peak white signal as observed on a waveform oscilloscope. Spots having a contrast $\geq 100\%$ are fully counted, spots having a contrast $> 50\%$ but $< 100\%$ will be considered as having half their actual size.

Spot size in % of raster height	Maximum number of spots	
	zone 1	zone 2
$> 1,2$	none	none
$\leq 1,0$ to $0,8$	none	1
$\leq 0,8$ to $0,4$	4	4
$\leq 0,4$ to $0,2$	4	4
$\leq 0,2$	*	*
total (max.)	8	

* Do not count spots of this size unless concentration causes a smudgy appearance.

Tubes are rejected for: smudges, lines, streaks, mottled, grainy or uneven background having contrast $> 50\%$.

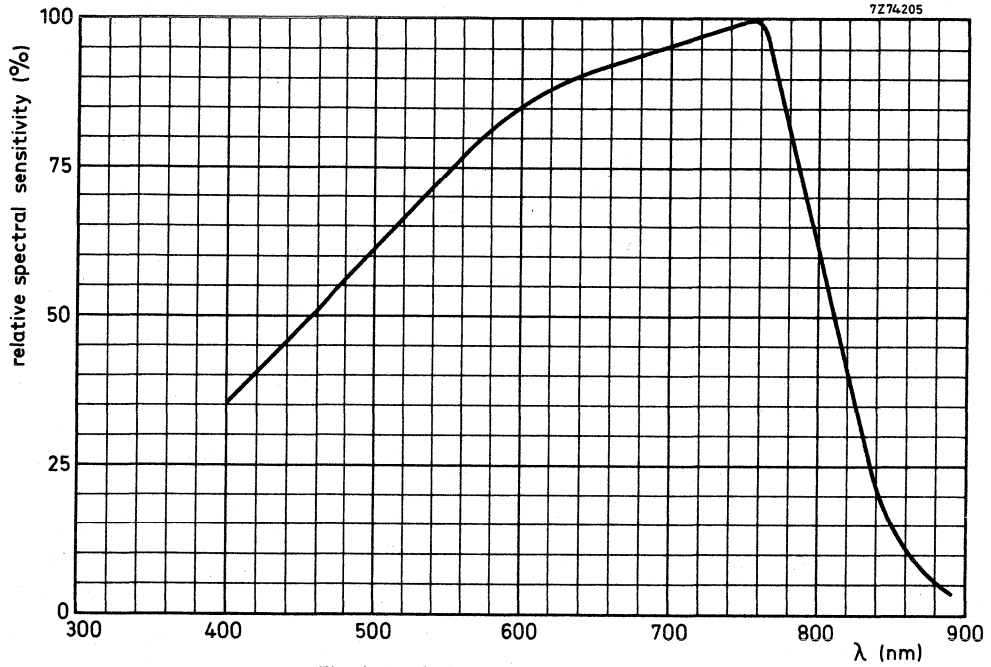

Fig. 1 Typical spectral response curve.

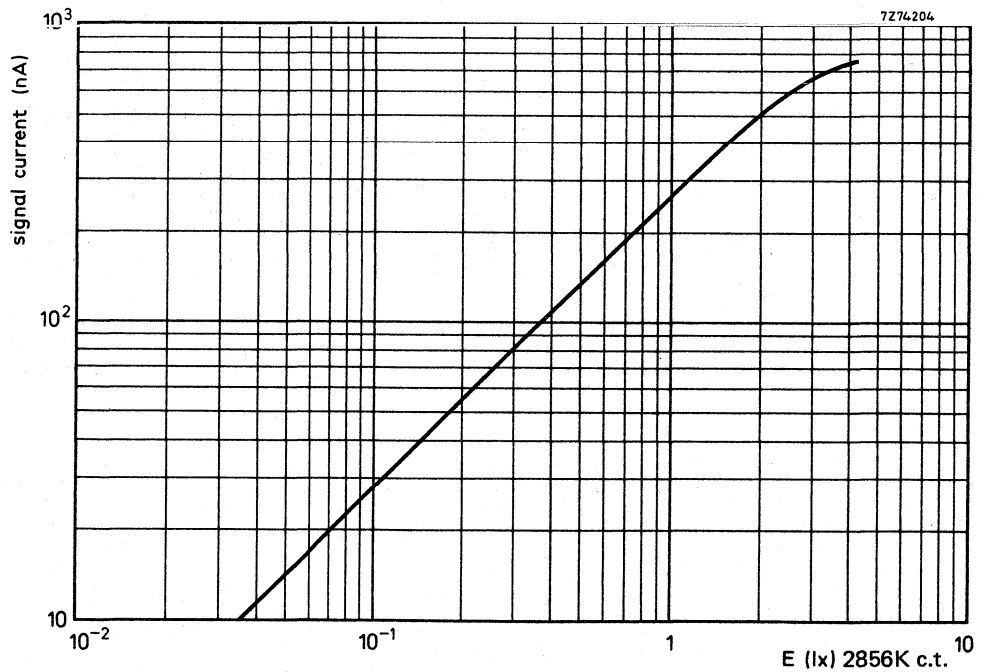

Fig. 2 Typical light transfer characteristic.

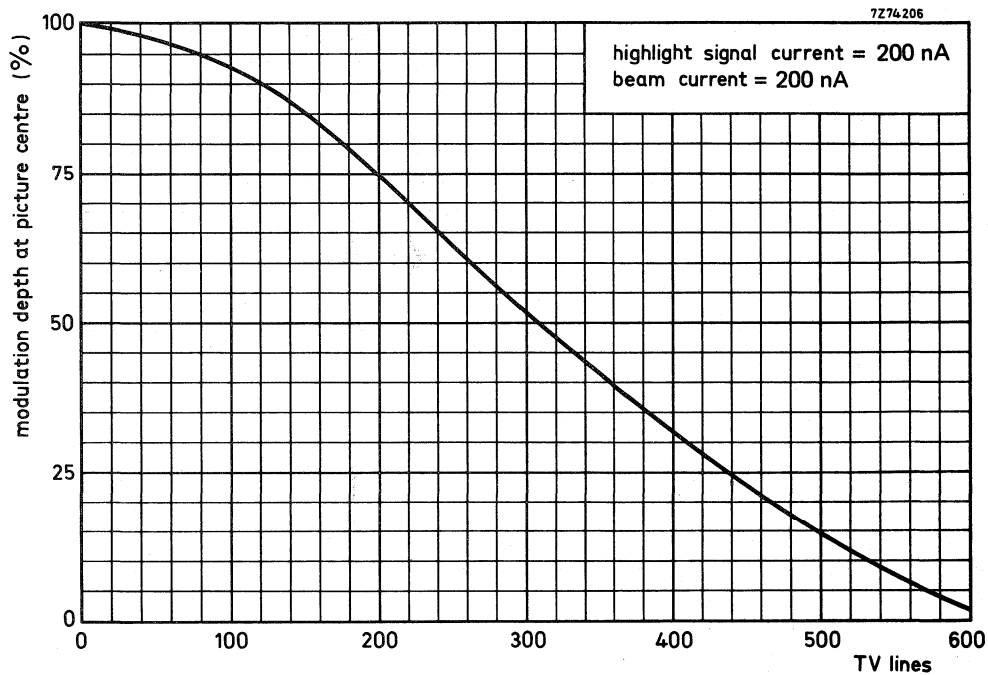

Fig. 3 Typical uncompensated square wave response curve.

CAMERA TUBE

NEWVICON® television camera tube with a photoconductive target composed of cadmium and zinc tellurides featuring high resolution and an extremely high sensitivity.

The XQ1275 is a 2/3 in diameter camera tube with low heater power, separate mesh, electrostatic focusing and magnetic deflection. It is mechanically interchangeable with vidicons like XQ1272 and has the same pin connections.

The XQ1275 is intended for use in ultra-compact cameras for security and surveillance applications, for example, where its high sensitivity and resolution, small size and low power consumption are essential.

QUICK REFERENCE DATA

Separate mesh		
Focusing		electrostatic
Deflection		magnetic
Diameter		17,7 mm
Length	max.	108 mm
Spectral response, max. at cut-off at	approx.	750 nm
	approx.	900 nm
Heater		6,3 V, 95 mA
Limiting resolution		600 TV lines

OPTICAL

Diagonal of quality rectangle on photoconductive layer (aspect ratio 3 : 4) 11 mm

Orientation of image on photoconductive layer:

The direction of the horizontal scan should be essentially parallel to the plane passing through the longitudinal tube axis and pin 4.

Spectral response, curve see Fig. 1

Faceplate thickness	1,5 mm
refractive index	1,61

HEATING Indirect by a.c. or d.c.; parallel or series supply

Heater voltage	V_f	6,3 V \pm 10%
Heater current, at $V_f = 6,3$ V	I_f	95 mA

When the tube is used in a series heater chain, the heater voltage must not exceed an r.m.s. value of 9,5 V when the supply is switched on.

CAPACITANCES

Signal electrode to all

$$C_{as} \approx 2 \text{ pF}$$

This capacitance, which is effectively the output impedance of the tube, increases when the tube is inserted into the deflection unit.

MECHANICAL DATA

Dimensions in mm

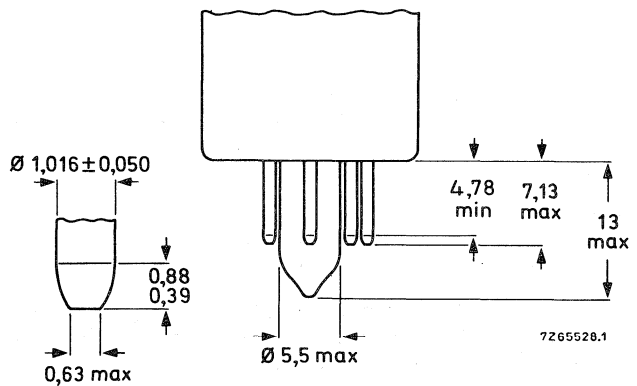
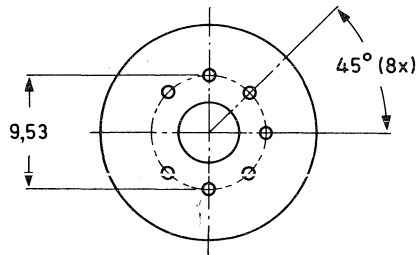
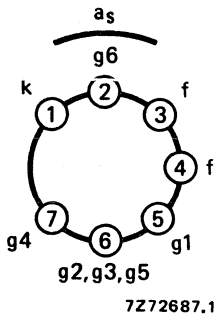
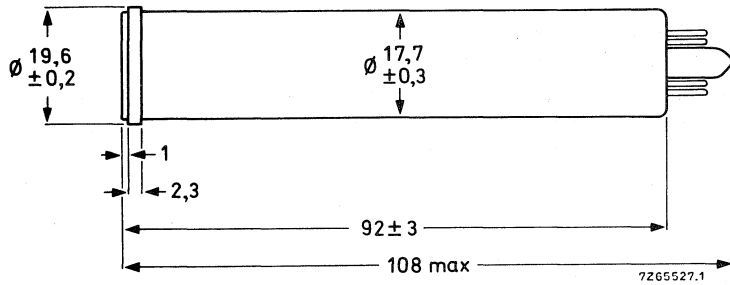

Mounting position: any

Net mass: $\approx 25 \text{ g}$

Base: JEDEC no. E7-91

ACCESSORIES

Socket	special miniature 7-pin, type 56049 or equivalent
Deflection coil unit	KV19G or equivalent

DEFLECTION

magnetic

FOCUSING

electrostatic (unipotential focusing
electron optics)

LIMITING VALUES (Absolute max. rating system)

for a scanned area of 6,6 mm x 8,8 mm.

"Full-size scanning" i.e. scanning of a 6,6 mm x 8,8 mm area of the photoconductive layer should always be applied. Underscanning, i.e. scanning of an area smaller than 6,6 mm x 8,8 mm, may cause permanent damage to the specified full-size area.

Signal electrode voltage	V_{as}	max.	50 V *
Grid 6 voltage	V_{g6}	max.	600 V
Grid 4 (beam focus electrode) voltage	V_{g4}	max.	350 V
Grid 2, 3 and 5 voltage	$V_{g2, 3 + 5}$	max.	350 V
Grid 1 voltage, negative	$-V_{g1}$	max.	300 V
	V_{g1}	max.	0 V
Cathode-to-heater voltage, peak positive	V_{kfp}	max.	125 V
	$-V_{kfp}$	max.	10 V
Output current, peak	I_{asp}	max.	800 nA **
Faceplate illumination	E	max.	10 000 lx ▲
Faceplate temperature, storage and operation	T	max.	70 °C
Cathode heating time before drawing cathode current	t_h	min.	1 min

* Newvicon tubes do not permit automatic sensitivity control by means of regulation of the signal electrode voltage. Adequate control is therefore to be achieved by other means (iris control and neutral density filters). If the tube is applied in cameras originally designed for vidicon tubes, the automatic sensitivity control circuitry should be made inoperative and the signal electrode voltage set to the value indicated in the test sheet. See General Operational Notes.

** Video amplifiers should be capable of handling signal electrode currents of this magnitude without overloading the amplifier or distorting the picture.

▲ White light, uniformly diffused over entire tube face.

Care must be taken not to focus the solar image on the target through a lens opening wider than $f: 11$ to avoid instantaneous breakdown.

OPERATING CONDITIONS AND PERFORMANCE

for a scanned area of 6,6 mm x 8,8 mm, a faceplate temperature of 25 to 35 °C and standard TV scanning rate.

Conditions

			notes
Signal electrode voltage	V_{as}	10 to 35 V	1
Grid 6 (decelerator) voltage	V_{g6}	500 V	2
Grid 4 (beam focus electrode) voltage	V_{g4}	35 to 55 V	3
Grid 2, 3 and 5 voltage	V_{g2+3+5}	300 V	2,4
Grid 1 voltage for picture cut off (no blanking applied)	V_{g1}	-80 to -30 V	
Blanking voltage, peak to peak			
when applied to grid 1		75 V	
when applied to cathode		20 V	
Flux density of adjustable alignment coil or magnet		0 to 0,4 mT	

Performance

Dark current (at 25 °C)

Signal current, white light
faceplate illumination 1 lx
c.t. 2856 K

Decay: residual signal current 60 ms
after cessation of the illumination
initial signal current 200 nA

Limiting resolution,
at picture centre
at picture corners

Average γ of transfer characteristic, see Fig. 2

Spurious signals (spots and blemishes)

	min.	typ.	max.	
		2	4	nA
I_s	200	260		nA
		10	15	%
	500	600		TV lines 5
	350	450		TV lines 5
		≈ 1		
				6

Notes

1. The signal electrode voltage should be adjusted to the value indicated by the tube manufacturer as printed on the envelope ($E_{s1} = \dots V$). To minimize picture sticking effects the signal electrode should be adjusted within a tolerance of $\pm 2 V$; the voltage drop across R_1 should be kept small. In the case of cathode blanking the voltage drop across the cathode resistor during read-out should be taken into account.
2. Grid 6 voltage must always be higher than grids 2 + 3 + 5 voltage.
The recommended ratio of grid 6 voltage to grids 2 + 3 + 5 voltage for best geometry and most uniform signal output depends upon the type of coil used and will be 5 : 3 for the recommended type (see "Accessories").
3. Adjusted for correct electrical focus.
4. Grids 2 + 3 + 5 voltage should be $> 250 V$ to provide sufficient beam current.
5. On EIA resolution test chart: faceplate illumination adjusted for a peak output current of 200 nA. The resolution is highly dependent on the coil used; the indicated figures are only valid for the recommended coil.

6. Conditions

The camera focused on a uniformly illuminated two-zone test pattern, the diameter of the centre zone (1) being equal to the raster height. Zone (2) being defined as the remainder of the scanned area.

Faceplate illumination adjusted to produce 200 nA signal current, beam current adjusted for correct stabilization.

Monitor set-up and contrast control adjusted for faint raster when lens of camera is capped and for non-blooming bright raster when lens of camera is uncapped.

Under above conditions the number and size of spots per zone visible in the monitor picture will not exceed the limits stated below. Both black and white spots must be counted, unless their contrast is less than 50% of peak white signal as observed on a waveform oscilloscope. Spots having a contrast $\geq 100\%$ are fully counted, spots having a contrast $> 50\%$ but $< 100\%$ will be considered as having half their actual size.

Spot size in % of raster height	Maximum number of spots	
	zone 1	zone 2
$> 1,2$	none	none
$\leq 1,0$ to 0,8	none	1
$\leq 0,8$ to 0,4	4	4
$\leq 0,4$ to 0,2	4	4
$\leq 0,2$	*	*
total (max.)	8	

* Do not count spots of this size unless concentration causes a smudgy appearance.

Tubes are rejected for: smudges, lines, streaks, mottled, grainy or uneven background having contrast $> 50\%$.

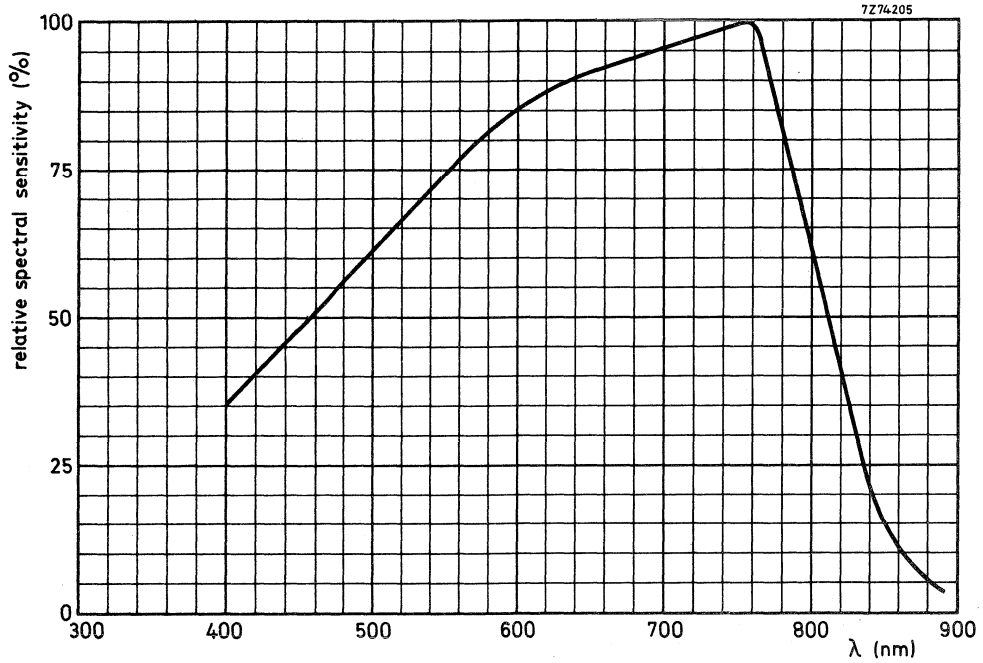

Fig. 1 Typical spectral response curve.

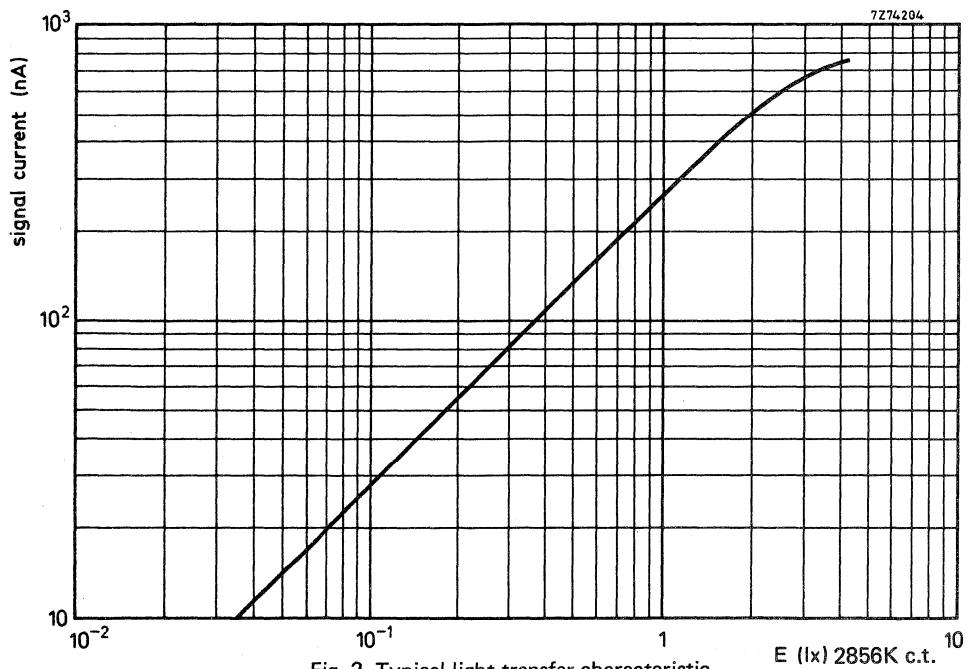

Fig. 2 Typical light transfer characteristic.

E (lx) 2856K c.t.

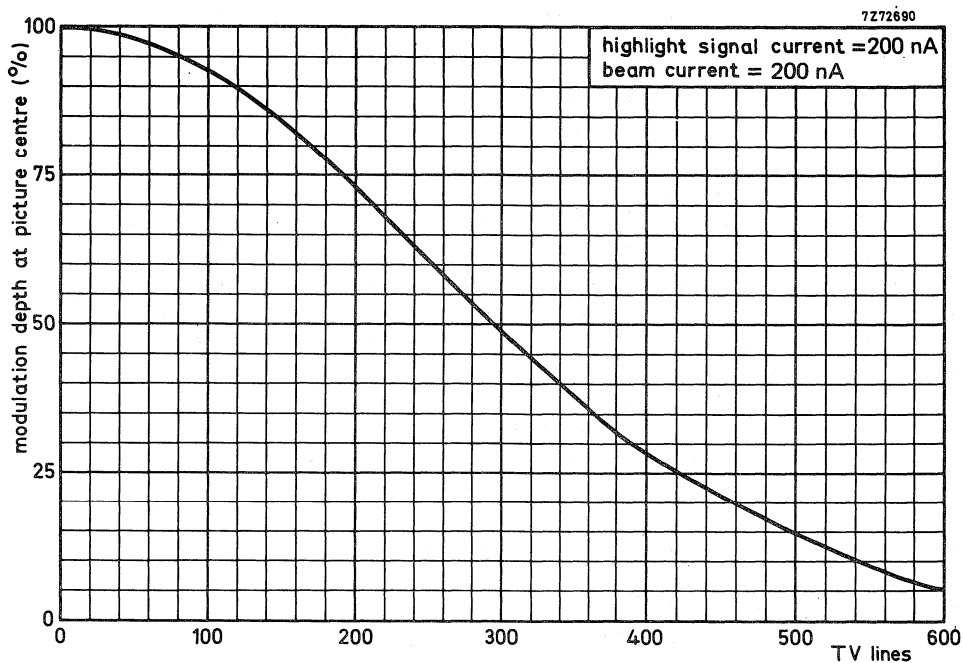

Fig. 3 Typical uncompensated square wave response curve.
Focusing electrostatic and magnetic combined.

CAMERA TUBE

NEWVICON® television camera tube with a photoconductive target composed of cadmium and zinc tellurides featuring high resolution and an extremely high sensitivity extending into the near infrared region.

The XQ1276 is a 2/3 in diameter camera tube with low heater power, separate mesh, magnetic focusing and deflection, and is mechanically interchangeable with vidicons like the XQ1271 and Newvicon tubes XQ1274 and has the same pin connections.

The XQ1276 is intended for use in ultra-compact cameras for security and surveillance applications, for example, where its high sensitivity extending into the near infrared, and its high resolution, small size and low power consumption are essential.

QUICK REFERENCE DATA

Separate mesh		
Focusing		magnetic
Deflection		magnetic
Diameter		17,7 mm
Length	max.	108 mm
Spectral response, max. at cut-off at	approx.	775 nm
	approx.	1000 nm
Heater		6,3 V, 95 mA
Limiting resolution		650 TV lines

OPTICAL

Diagonal of quality rectangle on photoconductive layer
(aspect ratio 3 : 4) 11 mm

Orientation of image on photoconductive layer:

The direction of the horizontal scan should be essentially parallel to the plane passing through the longitudinal tube axis and pin 4.

Spectral response curve see Fig. 1.

Face plate	
thickness	1,5 mm
refractive index	1,61

HEATING Indirect by a.c. or d.c.; parallel or series supply

Heater voltage	V_f	6,3 V \pm 10%
Heater current at $V_f = 6,3$ V	I_f	95 mA

When the tube is used in a series heater chain, the heater voltage must not exceed an r.m.s. value of 9,5 V when the supply is switched on.

® Registered trade mark for television camera tubes.

CAPACITANCES

Signal electrode to all

$$C_{as} \approx 2 \text{ pF}$$

This capacitance, which is effectively the output impedance of the tube, increases when the tube is inserted into the deflection and focusing coil unit.

MECHANICAL DATA

Dimensions in mm

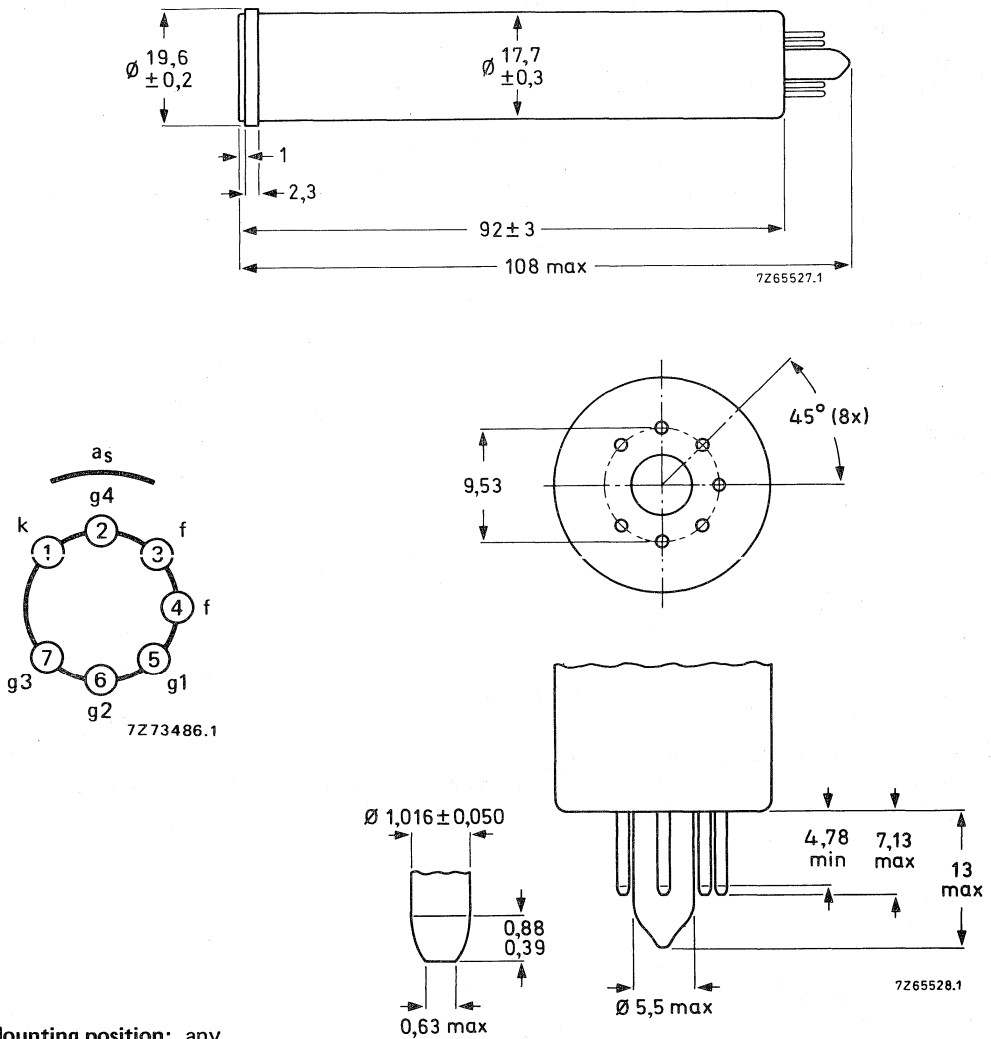

Mounting position: any

Net mass: $\approx 23 \text{ g}$

Base: JEDEC no. E7-91.

ACCESSORIES

Socket	special miniature 7-pin, type 56049 or equivalent
Deflection and focusing coil unit	KV12S or equivalent

DEFLECTION

magnetic

FOCUSING

magnetic

LIMITING VALUES (Absolute maximum rating system)

for a scanned area of 6,6 mm x 8,8 mm.

"Full-size scanning" i.e. scanning of a 6,6 mm x 8,8 mm area of the photoconductive layer should always be applied. Underscanning, i.e. scanning of an area smaller than 6,6 mm x 8,8 mm, may cause permanent damage to the specified full-size area.

Signal electrode voltage	V_{as}	max.	50 V*
Grid 4 voltage	V_{g4}	max.	750 V
Grid 3 voltage	V_{g3}	max.	750 V
Grid 2 voltage	V_{g2}	max.	350 V
Grid 1 voltage, negative	$-V_{g1}$	max.	300 V
positive	V_{g1}	max.	0 V
Cathode-to-heater voltage, peak positive	V_{kfp}	max.	125 V
peak negative	$-V_{kfp}$	max.	10 V
Output current, peak	I_{asp}	max.	800 nA**
Faceplate illumination	E	max.	10 000 lx [▲]
Faceplate temperature, storage and operation	T	max.	60 °C
Cathode heating time before drawing cathode current	t_h	min.	1 min

* Newwicon tubes do not permit automatic sensitivity control by means of regulation of the signal electrode voltage. Adequate control is therefore to be achieved by other means (iris control and neutral density filters). If the tube is applied in cameras originally designed for vidicon tubes, the automatic sensitivity control circuitry should be made inoperative and the signal electrode voltage set to the value indicated by the tube manufacturer. See General Operational Notes.

** Video amplifiers should be capable of handling signal-electrode currents of this magnitude without overloading the amplifier or distorting the picture.

▲ White light, uniformly diffused over entire tube face.

Care must be taken not to focus the solar image on the target through a lens opening wider than f : 11 to avoid instantaneous breakdown.

OPERATING CONDITIONS AND PERFORMANCE

for a scanned area of 6,6 mm x 8,8 mm, a faceplate temperature of 25 to 35 °C and standard TV scanning rate.

Conditions

			notes
Signal electrode voltage	V_{as}	10 to 25 V	1
Grid 4 (decelerator) voltage	V_{g4}	400 V	2
Grid 3 (beam focus electrode) voltage	V_{g3}	300 V	3
Grid 2 (accelerator) voltage	V_{g2}	300 V	
Grid 1 voltage for picture cut-off (no-blanking applied)	V_{g1}	-80 to -35 V	
Blanking voltage, peak to peak			
when applied to grid 1		75 V	
when applied to cathode		20 V	
Flux density at centre of focusing coil		5,0 to 5,6 mT	
Flux density of adjustable alignment coil or magnet		0 to 0,4 mT	

Performance

		min.	typ.	max.	
Dark current (at 25 °C)			5	10	nA
Signal current, white light faceplate illumination 1 lx c.t. 2856 K	I_s	250	320		nA
Signal current, near infrared illumination 1 lx, c.t. 2856 K infrared transmitting filter interposed (transmission curve see Fig. 2)	I_s	50	80		nA
Decay: residual signal current 60 ms after cessation of the illumination initial signal current 200 nA			8	13	%
Limiting resolution, at picture centre		550	650		TV lines 4
at picture corners		350	450		TV lines 4
Average γ of transfer characteristic, see Fig. 3			≈ 1		
Spurious signals (spots and blemishes)					5

Notes

1. The signal electrode voltage should be adjusted to the value indicated by the tube manufacturer as printed on the envelope ($E_{s_j} = \dots V$).
To minimize picture sticking effects the signal electrode voltage should be adjusted within a tolerance of $\pm 2 V$; the voltage drop across R_1 should be kept small. In case of cathode blanking the voltage drop across the cathode resistor during read-out should be taken into account.
2. Grid 4 voltage must always be higher than grid 3 voltage. The recommended ratio of grid 4 voltage to grid 3 voltage both for best geometry and most uniform signal output depends upon the type of coil unit used and will be 4: 3 for the recommended type (see 'Accessories').
3. Resolution decreases with decreasing grid 3 voltage. In general grid 3 should be operated above 250 V.
4. On EIA resolution test chart; faceplate illumination adjusted for a peak output current of 200 nA.
5. Conditions

The camera focused on a uniformly illuminated two-zone test pattern, the diameter of the centre zone (1) being equal to the raster height. Zone (2) being defined as the remainder of the scanned area.

Faceplate illumination adjusted to produce 200 nA signal current, beam current adjusted for correct stabilization.

Monitor set-up and contrast control adjusted for faint raster when lens of camera is capped and for non-blooming bright raster when lens of camera is uncapped.

Under above conditions the number and size of spots per zone visible in the monitor picture will not exceed the limits stated below. Both black and white spots must be counted, unless their contrast is less than 50% of peak white signal as observed on a waveform oscilloscope. Spots having a contrast $\geq 100\%$ are fully counted, spots having a contrast $> 50\%$ but $< 100\%$ will be considered as having half their actual size.

spot size in % of raster height	maximum number of spots	
	zone 1	zone 2
$> 1,2$	none	none
$\leq 1,2$ to 0,8	none	1
$\leq 0,8$ to 0,4	4	5
$\leq 0,4$ to 0,2	5	5
$\leq 0,2$	*	*
total (max.)	5	7

* Do not count spots of this size unless concentration causes a smudgy appearance.

Tubes are rejected for: smudges, lines, streaks, mottled, grainy or uneven background having contrast $> 50\%$.

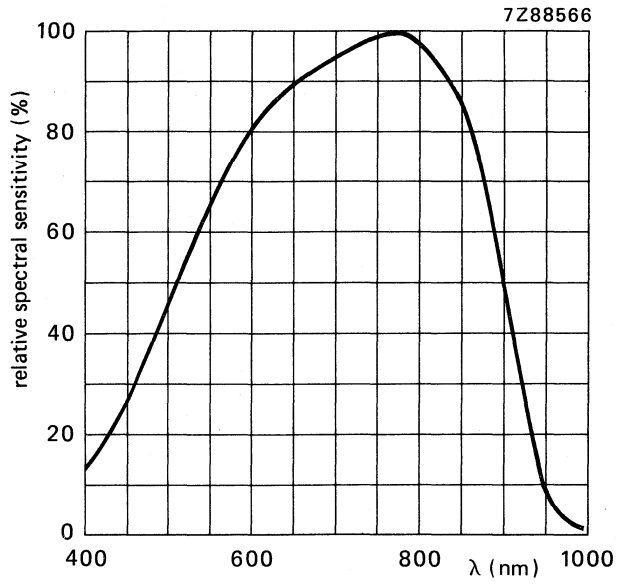

Fig.1 Typical spectral response curve.

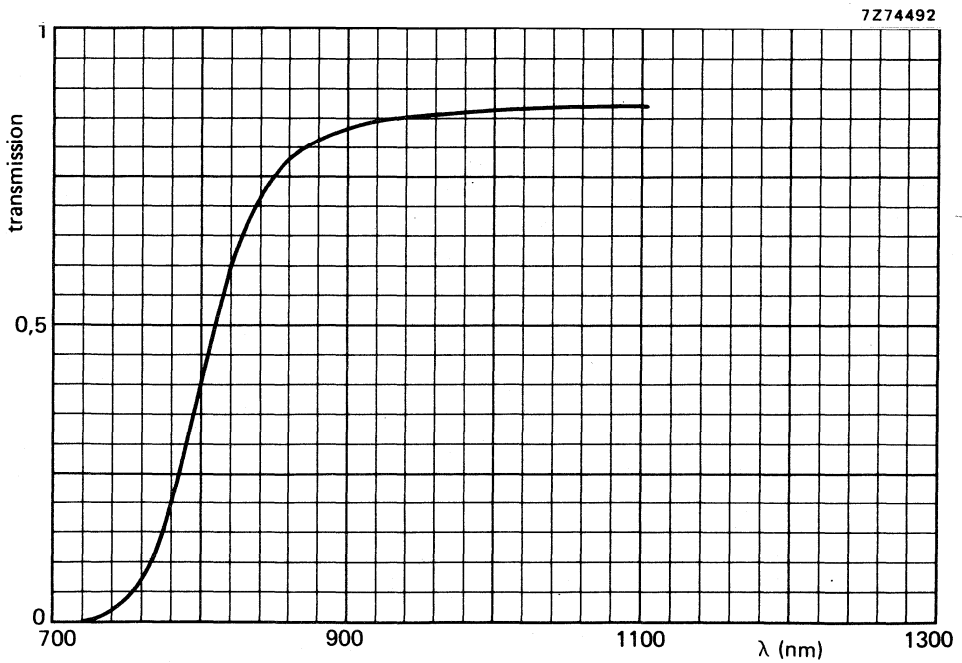

Fig.2 Transmission curve of infrared filter.

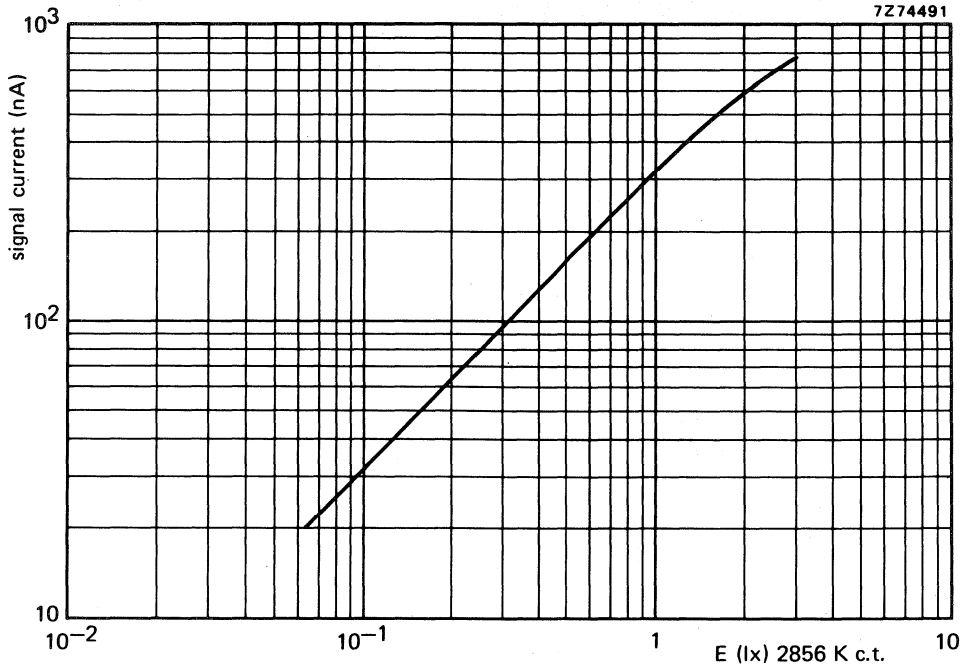

Fig.3 Typical light transfer characteristic.

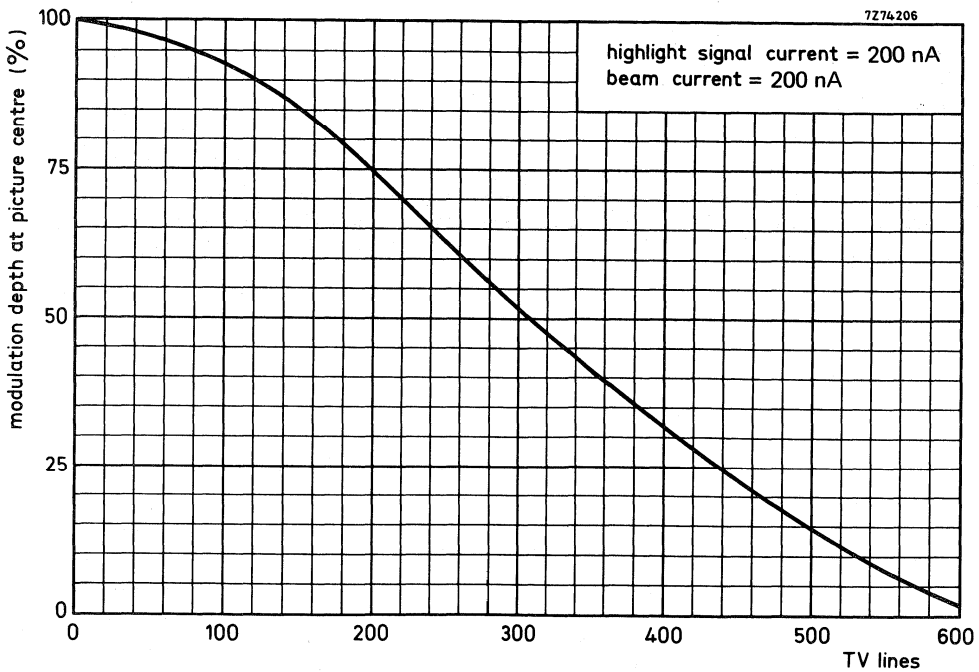

Fig.4 Typical uncompensated square wave response curve.

CAMERA TUBE

NEWVICON® television camera tube with a photoconductive target composed of cadmium and zinc tellurides featuring high resolution and an extremely high sensitivity extending into the near infrared region.

The XQ1277 is a 2/3 in diameter camera tube with low heater power, separate mesh, electrostatic focusing and magnetic deflection and is mechanically interchangeable with vidicons such as XQ1272, XQ1590 and newvicons XQ1275. Pin configuration is similar.

The XQ1277 is intended for use in ultra-compact cameras for security and surveillance applications, for example, where its high sensitivity extending into the near infrared, small size and low power consumption are essential.

QUICK REFERENCE DATA

Separate mesh		
Focusing (bi-potential focusing lens)		electrostatic
Deflection		magnetic
Diameter		17,7 mm
Length	max.	108 mm
Spectral response, max. at cut-off at	approx.	775 nm
	approx.	1000 nm
Heater		6,3 V, 95 mA
Limiting resolution		550 TV lines

OPTICAL

Diagonal of quality rectangle on photoconductive layer (aspect ratio 3 : 4)		11 mm
Orientation of image on photoconductive layer: The direction of the horizontal scan should be essentially parallel to the plane passing through the longitudinal tube axis and pin 4.		
Face plate thickness		1,5 mm
refractive index		1,61
Spectral response, curve see Fig. 1		

HEATING Indirect by a.c. or d.c.; parallel or series supply

Heater voltage	V_f	$6,3 \text{ V} \pm 10\%$
Heater current at $V_f = 6,3 \text{ V}$	I_f	95 mA

When the tube is used in a series heater chain, the heater voltage must not exceed an r.m.s. value of 9,5 V when the supply is switched on.

® Registered trade mark for television camera tubes.

CAPACITANCES

Signal electrode to all

$C_{as} \approx 2 \text{ pF}$

This capacitance, which is effectively the output impedance of the tube increases when the tube is inserted into the deflection unit.

MECHANICAL DATA

Dimensions in mm

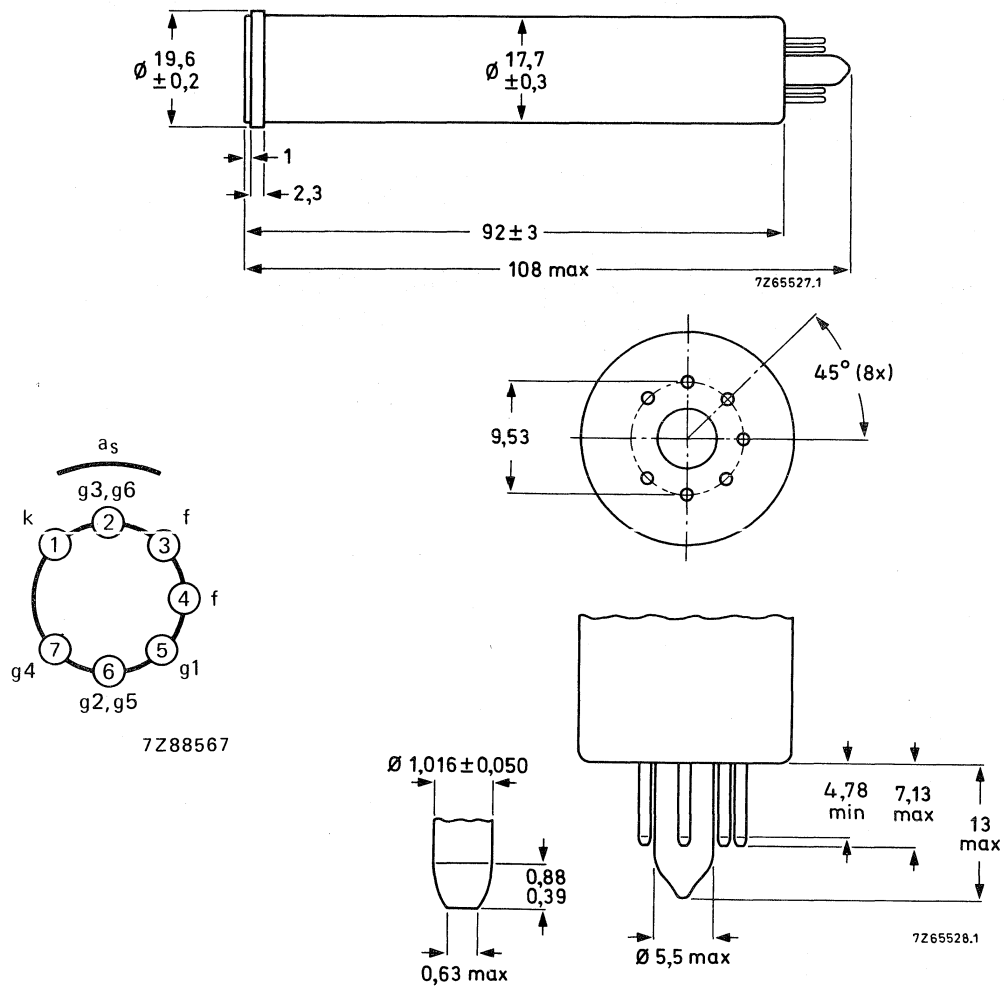

Mounting position: any

Net mass: $\approx 25 \text{ g}$

Base: JEDEC no. E7-91

ACCESSORIES

Socket	special miniature 7-pin, type 56049 or equivalent
Deflection coil unit	KV19G or equivalent

DEFLECTION

magnetic

FOCUSINGelectrostatic (bipotential focusing
electron optics)**LIMITING VALUES** (Absolute maximum rating system)

for a scanned area of 6,6 mm x 8,8 mm.

"Full-size scanning" i.e. scanning of a 6,6 mm x 8,8 mm area of the photoconductive layer should always be applied. Underscanning, i.e. scanning of an area smaller than 6,6 mm x 8,8 mm, may cause permanent damage to the specified full-size area.

Signal electrode voltage	V_{as}	max.	50 V*
Grid 3 and 6 voltage	$V_{g3,6}$	max.	750 V
Grid 4 voltage	V_{g4}	max.	350 V
Grid 2 and 5 voltage	$V_{g2,5}$	max.	350 V
Grid 1 voltage, negative	$-V_{g1}$	max.	300 V
positive	V_{g1}	max.	0 V
Cathode-to-heater voltage, peak positive	V_{kfp}	max.	125 V
peak negative	$-V_{kfp}$	max.	10 V
Output current, peak	I_{asp}	max.	800 nA**
Faceplate illumination	E	max.	10 000 lx ▲
Faceplate temperature, storage and operation	T	max.	60 °C
Cathode heating time before drawing cathode current	t_h	min.	1 min

* Newwicon tubes do not permit automatic sensitivity control by means of regulation of the signal electrode voltage. Adequate control is therefore to be achieved by other means (iris control and neutral density filters). If the tube is applied in cameras originally designed for vidicon tubes, the automatic sensitivity control circuitry should be made inoperative and the signal electrode voltage set to the value indicated on the tube. See General Operational Notes.

** Video amplifiers should be capable of handling signal electrode currents of this magnitude without overloading the amplifier or distorting the picture.

▲ White light, uniformly diffused over entire tube face.

Care must be taken not to focus the solar image on the target through a lens opening wider than $f : 11$ to avoid instantaneous breakdown.

OPERATING CONDITIONS AND PERFORMANCE

for a scanned area of 6,6 mm x 8,8 mm, a faceplate temperature of 25 to 35 °C and standard TV scanning rate.

Conditions

			notes
Signal electrode voltage	V_{as}	10 to 25 V	1
Grid 3 and 6 (decelerator) voltage	$V_{g3,6}$	500 V	2
Grid 4 (beam focus electrode) voltage	V_{g4}	60 to 85 V	3
Grid 2 and 5 voltage	$V_{g2,5}$	300 V	2, 4
Grid 1 voltage for picture cut-off (no blanking applied)	V_{g1}	-80 to -30 V	
Blanking voltage, peak to peak			
when applied to grid 1		75 V	
when applied to cathode		20 V	
Flux density of adjustable alignment coils or magnets		0 to 0,4 mT	

Performance

		min.	typ.	max.	
Dark current (at 25 °C)			5	10 nA	
Signal current, white light					
faceplate illumination 1 lx					
c.t. 2856 K	I_s	250	320	nA	
Signal current, near infrared					
illumination 1 lx, c.t. 2856 K					
infrared transmitting filter imposed					
(transmission curve, see Fig. 2)	I_s	50	80	nA	
Decay: residual signal current 60 ms					
after cessation of the illumination					
initial signal current 200 nA			10	15 %	
Limiting resolution					
at picture centre		500	550	TV lines	5
at corner of picture		400	450	TV lines	5
Average γ of transfer characteristic, see Fig. 3			≈ 1		
Spurious signals (spots and blemishes)					6

Notes

1. The signal electrode voltage should be adjusted to the value indicated by the tube manufacturer as printed on the envelope ($E_{sj} = \dots V$). To minimize picture sticking effects the signal electrode should be adjusted within a tolerance of $\pm 2 V$; the voltage drop across R_1 should be kept small. In the case of cathode blanking the voltage drop across the cathode resistor during read-out should be taken into account.
2. Grids 3 + 6 voltage must always be higher than grids 2 + 5 voltage.
The recommended ratio of grids 3 + 6 voltage to grids 2 + 5 voltage for best geometry and most uniform signal output depends upon the type of coil used and will be 5 : 3 for the recommended types (see "Accessories").
3. Adjusted for correct electrical focus. This voltage range is higher than that of unipotential electrostatic focus, such as XQ1275.
4. Grids 2 + 5 voltage should be $> 250 V$ to provide sufficient beam current.
5. On EIA resolution test chart: faceplate illumination adjusted for a peak output current of 200 nA. The resolution is highly dependent on the coil used; the indicated figures are only valid for the recommended coil.
6. **Conditions**

The camera focused on a uniformly illuminated two-zone test pattern, the diameter of the centre zone (1) being equal to the raster height. Zone (2) being defined as the remainder of the scanned area.

Faceplate illumination adjusted to produce 200 nA signal current, beam current adjusted for correct stabilization.

Monitor set-up and contrast control adjusted for faint raster when lens of camera is capped and for non-blooming bright raster when lens of camera is uncapped.

Under above conditions the number and size of spots per zone visible in the monitor picture will not exceed the limits stated below. Both black and white spots must be counted, unless their contrast is less than 50% of peak white signal as observed on a waveform oscilloscope. Spots having a contrast $\geq 100\%$ are fully counted, spots having a contrast $> 50\%$ but $< 100\%$ will be considered as having half their actual size.

Spot size in % of raster height	Maximum number of spots	
	zone 1	zone 2
$> 1,2$	none	none
$\leq 1,2$ to 0,8	none	1
$\leq 0,8$ to 0,4	4	5
$\leq 0,4$ to 0,2	5	5
$\leq 0,2$	*	*
total (max.)	5	7

- * Do not count spots of this size unless concentration causes a smudgy appearance.
Tubes are rejected for: smudges, lines, streaks, mottled, grainy or uneven background having contrast $> 50\%$.

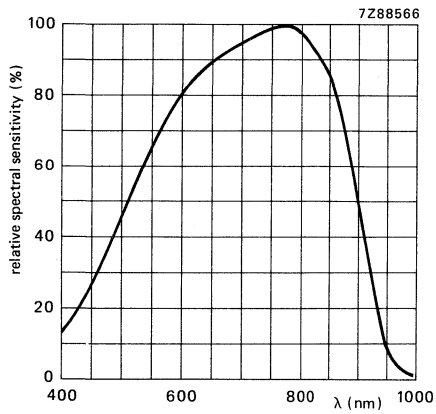

Fig. 1 Typical spectral response curve.

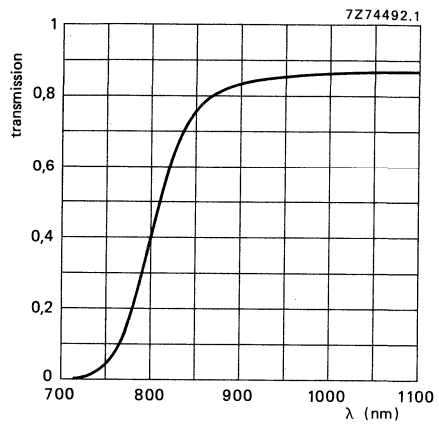

Fig. 2 Transmission curve of infrared filter.

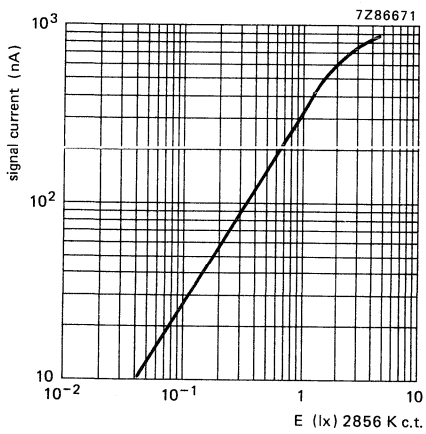

Fig. 3 Typical light transfer characteristic.

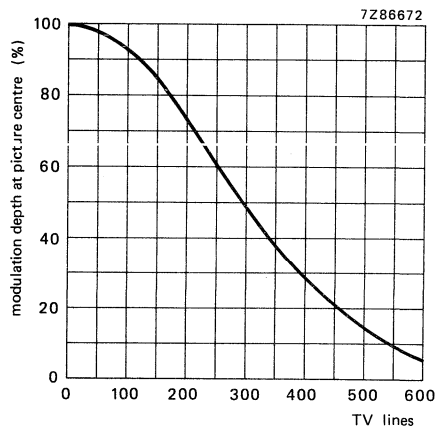

Fig. 4 Typical uncompensated square wave response curve. Highlight signal current 200 nA; beam current 200 nA. Focusing electrostatic and magnetic combined.

CAMERA TUBE

NEWVICON® television camera tube with a photoconductive target composed of cadmium and zinc tellurides featuring high resolution and an extremely high sensitivity.

The XQ1278 is a 2/3 in diameter camera tube with low heater power, separate mesh, electrostatic focusing and magnetic deflection and is mechanically interchangeable with vidicons such as XQ1272, XQ1590 and newvicons XQ1275. Pin configuration is similar.

The XQ1278 is intended for use in ultra-compact cameras for security and surveillance applications, for example, where its high sensitivity, small size and low power consumption are essential.

QUICK REFERENCE DATA

Separate mesh	
Focusing (bi-potential focusing lens)	electrostatic
Deflection	magnetic
Diameter	17,7 mm
Length	max. 108 mm
Spectral response, max. at cut-off at	approx. 750 nm approx. 900 nm
Heater	6,3 V, 95 mA
Limiting resolution	550 TV lines

OPTICAL

Diagonal of quality rectangle on photoconductive layer
(aspect ratio 3 : 4) 11 mm

Orientation of image on photoconductive layer:

The direction of the horizontal scan should be essentially parallel to the plane passing through the longitudinal tube axis and pin 4.

Face plate
thickness 1,5 mm
refractive index 1,61

Spectral response, curve see Fig. 1

HEATING Indirect by a.c. or d.c.; parallel or series supply

Heater voltage	V_f	6,3 V \pm 10%
Heater current at $V_f = 6,3$ V	I_f	95 mA

When the tube is used in a series heater chain, the heater voltage must not exceed an r.m.s. value of 9,5 V when the supply is switched on.

CAPACITANCES

Signal electrode to all

$C_{as} \approx 2 \text{ pF}$

This capacitance, which is effectively the output impedance of the tube increases when the tube is inserted into the deflection unit.

MECHANICAL DATA

Dimensions in mm

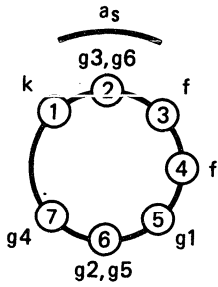
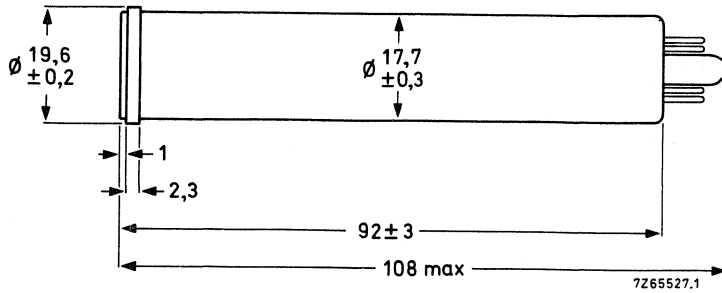

7288567

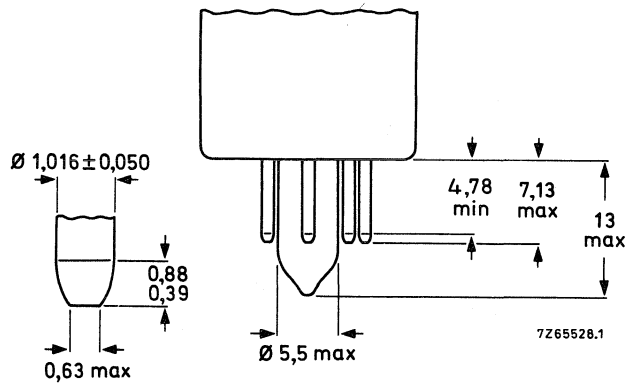
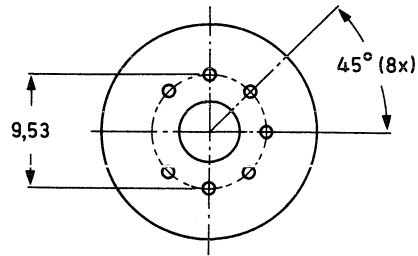

Mounting position: any

Net mass: $\approx 25 \text{ g}$

Base: JEDEC no. E7-91

ACCESSORIES

Socket	special miniature 7-pin, type 56049 or equivalent
Deflection coil unit	KV19G or equivalent

DEFLECTION

magnetic

FOCUSING

electrostatic (bipotential focusing
electron optics)

LIMITING VALUES (Absolute maximum rating system)

for a scanned area of 6,6 mm x 8,8 mm.

"Full-size scanning" i.e. scanning of a 6,6 mm x 8,8 mm area of the photoconductive layer should always be applied. Underscanning, i.e. scanning of an area smaller than 6,6 mm x 8,8 mm, may cause permanent damage to the specified full-size area.

Signal electrode voltage	V_{as}	max.	50 V*
Grid 3 and 6 voltage	$V_{g3,6}$	max.	750 V
Grid 4 voltage	V_{g4}	max.	350 V
Grid 2 and 5 voltage	$V_{g2,5}$	max.	350 V
Grid 1 voltage, negative	$-V_{g1}$	max.	300 V
positive	V_{g1}	max.	0 V
Cathode-to-heater voltage, peak positive	V_{kfp}	max.	125 V
peak negative	$-V_{kfp}$	max.	10 V
Output current, peak	I_{asp}	max.	800 nA**
Faceplate illumination	E	max.	10 000 lx [▲]
Faceplate temperature, storage and operation	T	max.	70 °C
Cathode heating time before drawing cathode current	t_h	min.	1 min

* Newvicon tubes do not permit automatic sensitivity control by means of regulation of the signal electrode voltage. Adequate control is therefore to be achieved by other means (iris control and neutral density filters). If the tube is applied in cameras originally designed for vidicon tubes, the automatic sensitivity control circuitry should be made inoperative and the signal electrode voltage set to the value indicated on the tube. See General Operational Notes.

** Video amplifiers should be capable of handling signal electrode currents of this magnitude without overloading the amplifier or distorting the picture.

▲ White light, uniformly diffused over entire tube face.

Care must be taken not to focus the solar image on the target through a lens opening wider than f : 11 to avoid instantaneous breakdown.

OPERATING CONDITIONS AND PERFORMANCE

for a scanned area of 6,6 mm x 8,8 mm, a faceplate temperature of 25 to 35 °C and standard TV scanning rate.

Conditions

			notes
Signal electrode voltage	V_{as}	10 to 35 V	1
Grid 3 and 6 (decelerator) voltage	$V_{g3,6}$	500 V	2
Grid 4 (beam focus electrode) voltage	V_{g4}	60 to 85 V	3
Grid 2 and 5 voltage	$V_{g2,5}$	300 V	2, 4
Grid 1 voltage for picture cut-off (no blanking applied)	V_{g1}	-80 to -30 V	
Blanking voltage, peak to peak			
when applied to grid 1		75 V	
when applied to cathode		20 V	
Flux density of adjustable alignment coil or magnet		0 to 0,4 mT	

Performance

	min.	typ.	max.	
Dark current (at 25 °C)		2	4 nA	
Signal current, white light faceplate illumination 1 lx c.t. 2856 K	I_s 200	260	nA	
Decay: residual signal current 60 ms after cessation of the illumination initial signal current 200 nA		10	15 %	
Limiting resolution, at picture centre	500	550	TV lines	5
at corner of picture	400	450	TV lines	5
Average γ of transfer characteristic, see Fig. 2		≈ 1		
Spurious signals (spots and blemishes)				6

Notes

1. The signal electrode voltage should be adjusted to the value indicated by the tube manufacturer as printed on the envelope ($E_{sj} = \dots V$). To minimize picture sticking effects the signal electrode should be adjusted within a tolerance of $\pm 2 V$; the voltage drop across R_1 should be kept small. In the case of cathode blanking the voltage drop across the cathode resistor during read-out should be taken into account.
2. Grids 3 + 6 voltage must always be higher than grids 2 + 5 voltage.
The recommended ratio of grids 3 + 6 voltage to grids 2 + 5 voltage for best geometry and most uniform signal output depends upon the type of coil used and will be 5 : 3 for the recommended types (see "Accessories").
3. Adjusted for correct electrical focus. This voltage range is higher than that of unipotential electrostatic focus, such as XQ1275.
4. Grids 2 + 5 voltage should be $> 250 V$ to provide sufficient beam current.
5. On EIA resolution test chart: faceplate illumination adjusted for a peak output current of 200 nA. The resolution is highly dependent on the coil used; the indicated figures are only valid for the recommended coil.
6. **Conditions**

The camera focused on a uniformly illuminated two-zone test pattern, the diameter of the centre zone (1) being equal to the raster height. Zone (2) being defined as the remainder of the scanned area.

Faceplate illumination adjusted to produce 200 nA signal current, beam current adjusted for correct stabilization.

Monitor set-up and contrast control adjusted for faint raster when lens of camera is capped and for non-blooming bright raster when lens of camera is uncapped.

Under above conditions the number and size of spots per zone visible in the monitor picture will not exceed the limits stated below. Both black and white spots must be counted, unless their contrast is less than 50% of peak white signal as observed on a waveform oscilloscope. Spots having a contrast $\geq 100\%$ are fully counted, spots having a contrast $> 50\%$ but $< 100\%$ will be considered as having half their actual size.

Spot size in % of raster height	Maximum number of spots	
	zone 1	zone 2
$> 1,2$	none	none
$\leq 1,0$ to 0,8	none	1
$\leq 0,8$ to 0,4	4	4
$\leq 0,4$ to 0,2	4	4
$\leq 0,2$	*	*
total (max.)	8	

* Do not count spots of this size unless concentration causes a smudgy appearance.
Tubes are rejected for: smudges, lines, streaks, mottled, grainy or uneven background having contrast $> 50\%$.

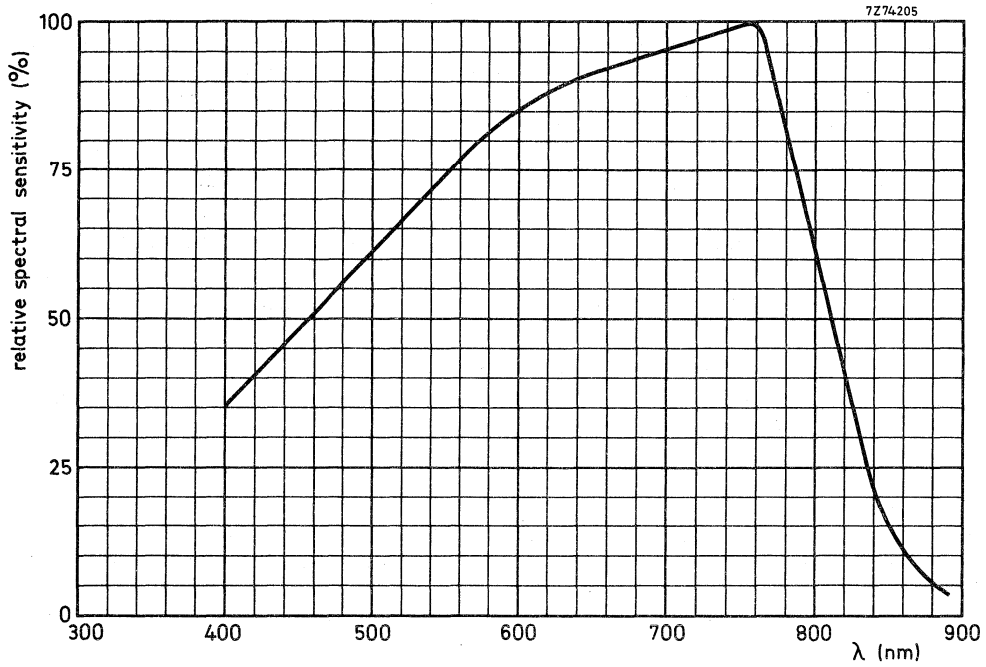

Fig. 1 Typical spectral response curve.

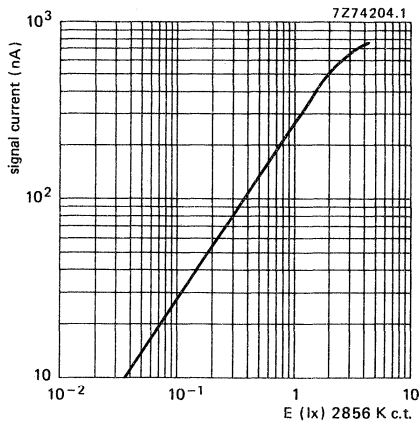

Fig. 2 Typical light transfer characteristic.

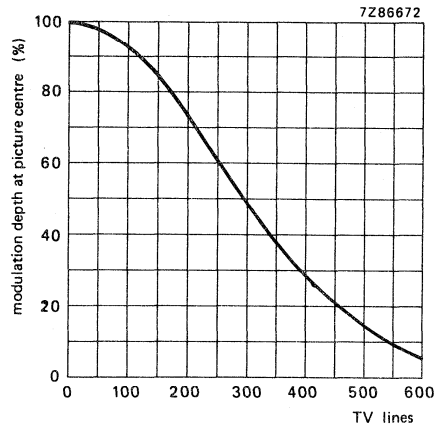

Fig. 3 Typical uncompensated square wave response curve. Highlight signal current 200 nA; beam current 200 nA. Focusing electrostatic and magnetic combined.

CAMERA TUBE

Newvicon® camera tube, mechanically and electron-optically identical to the XQ1274, the major difference being the radiation resistant (anti-browning) faceplate.

The XQ1380 is intended for use in compact cameras which are subjected to high doses of ionizing radiation.

RADIATION RESISTANT FACEPLATE

The faceplate of the XQ1380 is made of a special type of glass and does not turn brown under the influence of high doses of gamma radiation.

- Maximum dose rate per hour: 5×10^5 Röntgen/hour
- Maximum cumulative dose: 5×10^7 Röntgen
- Maximum decrease of transmission of faceplate:

Maximum decrease	After a cumulative dose of
3%	10^5 Röntgen
10%	10^6 Röntgen
15%	5×10^7 Röntgen

- Maximum increase of dark current at 25 °C after a cumulative dose of 5×10^7 Röntgen: 75%

SENSITIVITY

The typical sensitivity of the XQ1380 is approximately 10% less than for the XQ1274.

For all other information see data of XQ1274.

CAMERA TUBE

Newvicon® camera tube, mechanically and electron-optically identical to the XQ1275, the major difference being the radiation resistant (anti-browning) faceplate.

The XQ1381 is intended for use in compact cameras which are subjected to high doses of ionizing radiation.

RADIATION RESISTANT FACEPLATE

The faceplate of the XQ1381 is made of a special type of glass and does not turn brown under the influence of high doses of gamma radiation.

- Maximum dose rate per hour: 5×10^5 Röntgen/hour
- Maximum cumulative dose: 5×10^7 Röntgen
- Maximum decrease of transmission of faceplate:

Maximum decrease	After a cumulative dose of
3%	10^5 Röntgen
10%	10^6 Röntgen
15%	5×10^7 Röntgen

- Maximum increase of dark current at 25 °C after a cumulative dose of 5×10^7 Röntgen: 75%

SENSITIVITY

The typical sensitivity of the XQ1381 is approximately 10% less than for the XQ1275.

For all other information see data of XQ1275.

CAMERA TUBE

NEWVICON® television camera tube with a photoconductive target composed of cadmium and zinc tellurides featuring high resolution and an extremely high sensitivity.

The XQ1440 is a 1 in diameter camera tube with low heater power, separate mesh, magnetic focusing and deflection, and is mechanically interchangeable with vidicons like the XQ1240 and has the same pin connections.

The XQ1440 is intended for use in cameras for security and surveillance applications, for example, where its high sensitivity and resolution are essential.

QUICK REFERENCE DATA

Separate mesh			
Focusing		magnetic	
Deflection		magnetic	
Diameter		25,9	mm
Length		159	mm
Spectral response, max. at	approx.	750	nm
cut-off at	approx.	900	nm
Heater		6,3 V, 95	mA
Limiting resolution		750	TV lines

OPTICAL

Diagonal of quality rectangle on photoconductive layer (aspect ratio 3 : 4) 16 mm

Orientation of image on photoconductive layer:

The direction of the horizontal scan should be essentially parallel to the plane passing through the longitudinal tube axis and the short index pin.

Spectral response curve see Fig. 1

Faceplate thickness	2,5 mm
refractive index	1,61

HEATING

Indirect by a.c. or d.c.; parallel or series supply

Heater voltage	V_f	6,3 V \pm 10%
----------------	-------	-----------------

Heater current, at $V_f = 6,3$ V	I_f	95 mA
----------------------------------	-------	-------

When the tube is used in a series heater chain, the heater voltage must not exceed an r.m.s. value of 9,5 V when the supply is switched on.

CAPACITANCES

Signal electrode to all

$$C_{as} \approx 4,6 \text{ pF}$$

This capacitance, which is effectively the output impedance of the tube, increases when the tube is inserted into the deflection and focusing coil unit.

MECHANICAL DATA

Dimensions in mm

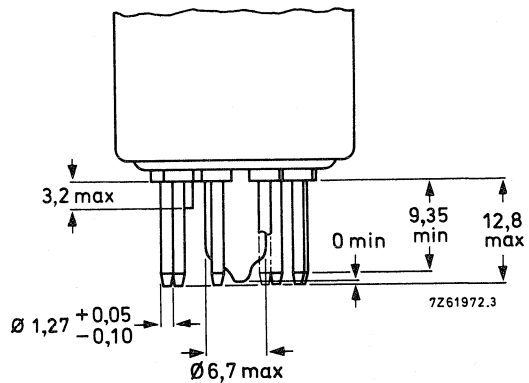
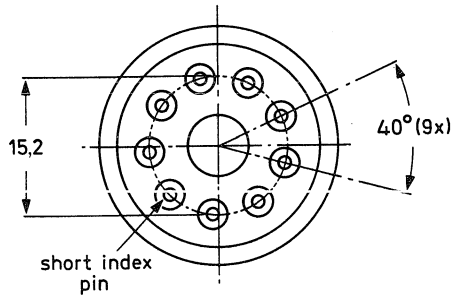
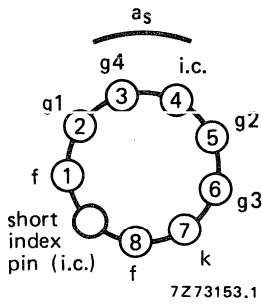
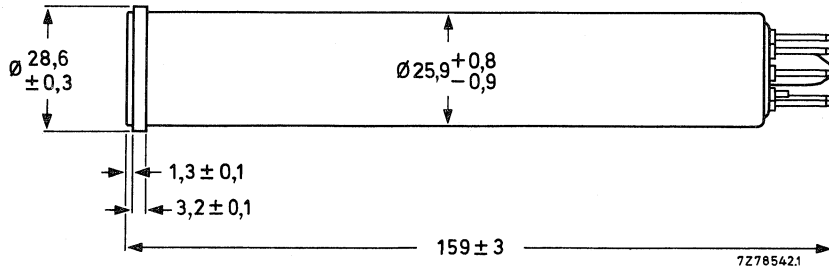

Base: JEDEC no. E8-11
 Mounting position: any
 Net mass: $\approx 62 \text{ g}$

ACCESSORIES

Socket	56602 or equivalent
Deflection and focusing coil unit	KV9G or equivalent

DEFLECTION

magnetic

FOCUSING

magnetic

LIMITING VALUES (Absolute maximum rating system)
for a scanned area of 9,6 mm x 12,8 mm.

"Full-size scanning" i.e. scanning of a 9,6 mm x 12,8 mm area of the photoconductive layer should always be applied. Underscanning, i.e. scanning of an area smaller than 9,6 mm x 12,8 mm, may cause permanent damage to the specified full-size area.

Signal electrode voltage	V_{as}	max.	50 V *
Grid 4 voltage	V_{g4}	max.	1000 V
Grid 3 voltage	V_{g1}	max.	1000 V
Grid 2 voltage	V_{g2}	max.	750 V
Grid 1 voltage, negative	$-V_{g1}$	max.	300 V
positive	V_{g1}	max.	0 V
Cathode-to-heater voltage, peak positive	V_{kfp}	max.	125 V
peak negative	$-V_{kfp}$	max.	10 V
Output current, peak	I_{asp}	max.	800 nA**
Faceplate illumination	E	max.	10 000 lx [▲]
Faceplate temperature, storage and operation	T	max.	70 °C
Cathode heating time before drawing cathode current	t_h	min.	1 min

* Newvicon tubes do not permit automatic sensitivity control by means of regulation of the signal electrode voltage. Adequate control is therefore to be achieved by other means (iris control and neutral density filters). If the tube is applied in cameras originally designed for vidicon tubes, the automatic sensitivity control circuitry should be made inoperative and the signal electrode voltage set to the value indicated by the tube manufacturer. See General Operational Notes.

** Video amplifiers should be capable of handling signal electrode currents of this magnitude without overloading the amplifier or distorting the picture.

▲ White light, uniformly diffused over entire tube face.

Care must be taken not to focus the solar image on the target through a lens opening wider than $f: 11$ to avoid instantaneous breakdown.

OPERATING CONDITIONS AND PERFORMANCE

for a scanned area of 9,6 mm x 12,8 mm, a faceplate temperature of 25 to 35 °C and standard TV scanning rate.

Conditions

			notes
Signal electrode voltage	V_{as}	10 to 35 V	1
Grid 4 (decelerator) voltage	V_{g4}	500 V	2
Grid 3 (beam focus electrode) voltage	V_{g3}	300 V	3
Grid 2 (accelerator) voltage	V_{g2}	300 V	
Grid 1 voltage for picture cut-off (no blanking applied)	V_{g1}	-100 to -45 V	
Blanking voltage, peak to peak			
when applied to grid 1		75 V	
when applied to cathode		20 V	
Flux density at centre of focusing coil		3,8 to 4,4 mT	
Flux density of adjustable alignment coil or magnet		0 to 0,4 mT	

Performance

		min.	typ.	max.	
Dark current (at 25 °C)			3,5	7	nA
Signal current, white light faceplate illumination 0,5 lx c.t. 2856 K	I_s	200	240		nA
Decay: residual signal current 60 ms after cessation of the illumination (c.t. 2856 K), initial signal current 200 nA			17		25%
Limiting resolution, at picture centre		650	750		TV lines 4
at picture corners		400	500		TV lines 4
Average γ of transfer characteristic			≈ 1		
Spurious signals (spots and blemishes)					5

Notes

1. The signal electrode voltage should be adjusted to the value indicated by the tube manufacturer as printed on the envelope ($E_{sj} = \dots V$).
To minimize picture sticking effects the signal electrode voltage should be adjusted within a tolerance of $\pm 2 V$; the voltage drop across R_1 should be kept small. In the case of cathode blanking the voltage drop across the cathode resistor during read-out should be taken into account.
2. Grid 4 voltage must always be higher than grid 3 voltage. The recommended ratio of grid 4 voltage to grid 3 voltage both for best geometry and most uniform signal output depends upon the type of coil unit used and will be 5 : 3 for the recommended type (see "Accessories").
3. Resolution decreases with decreasing grid 3 voltage. In general grid 3 should be operated above 250 V.
4. On EIA resolution test chart: faceplate illumination adjusted for a peak output current of 200 nA.
5. **Conditions**

The camera focused on a uniformly illuminated two-zone test pattern, the diameter of the centre zone (1) being equal to the raster height. Zone (2) being defined as the remainder of the scanned area. Faceplate illumination adjusted to produce 200 nA signal current, beam current adjusted for correct stabilization.

Monitor set-up and contrast control adjusted for faint raster when lens of camera is capped and for non-blooming bright raster when lens of camera is uncapped.

Under above conditions the number and size of spots per zone visible in the monitor picture will not exceed the limits stated below. Both black and white spots must be counted, unless their contrast is less than 50% of peak white signal as observed on a waveform oscilloscope. Spots having a contrast $\geq 100\%$ are fully counted, spots having a contrast $> 50\%$ but $< 100\%$ will be considered as having half their actual size.

Spot size in % of raster height	Maximum number of spots	
	zone 1	zone 2
$> 1,2$	none	none
$\leq 1,0$ to $0,8$	none	1
$\leq 0,8$ to $0,4$	4	4
$\leq 0,4$ to $0,2$	4	4
$\leq 0,2$	*	*
total (max.)	8	

* Do not count spots of this size unless concentration causes a smudgy appearance.
Tubes are rejected for: smudges, lines, streaks, mottled, grainy or uneven background having contrast $> 50\%$.

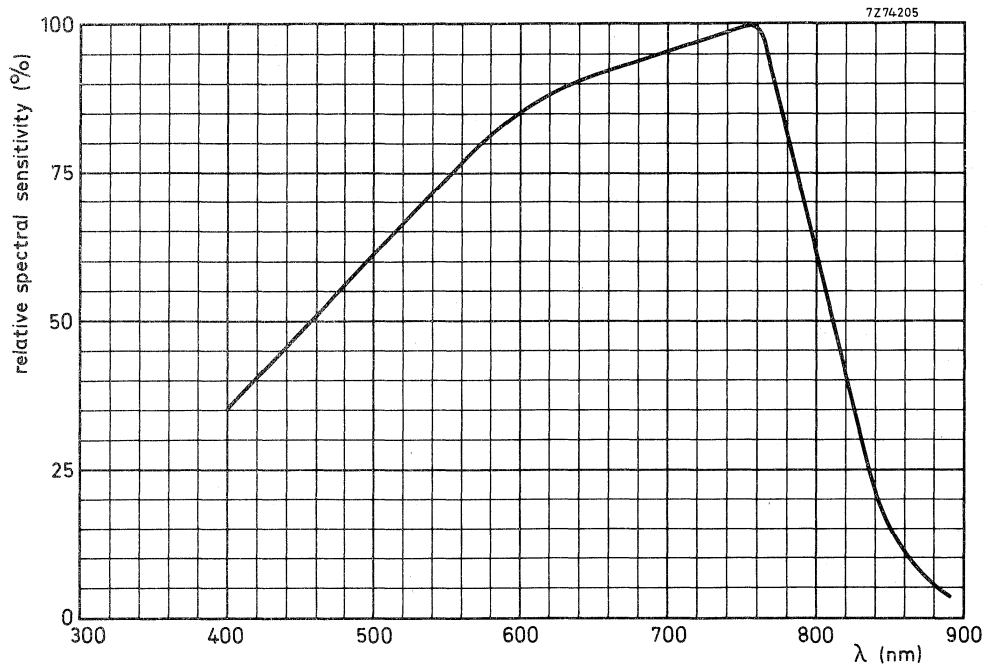

Fig. 1 Typical spectral response curve.

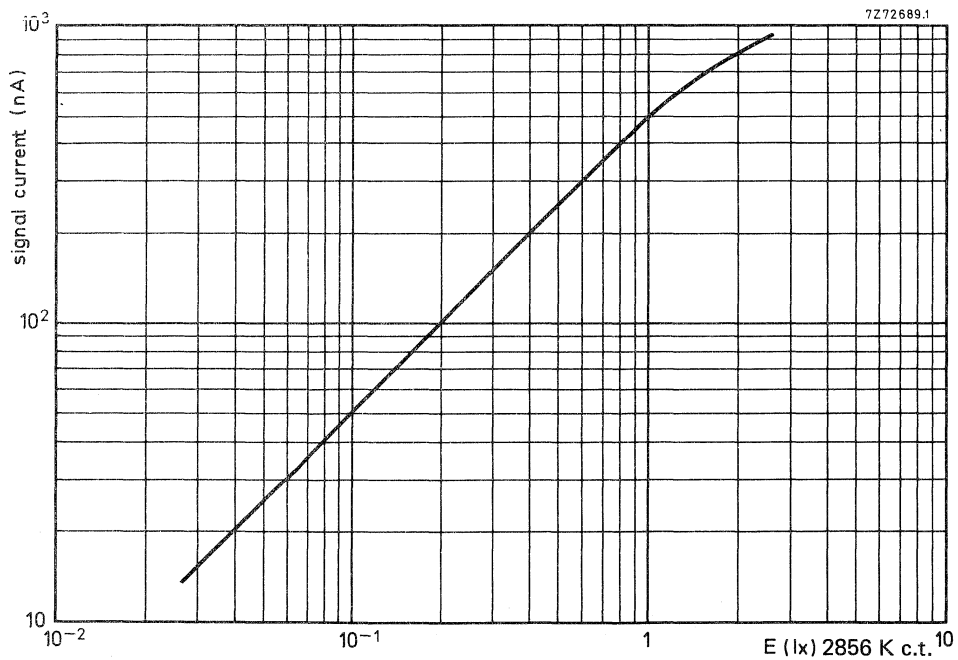

Fig. 2 Typical light transfer characteristic.

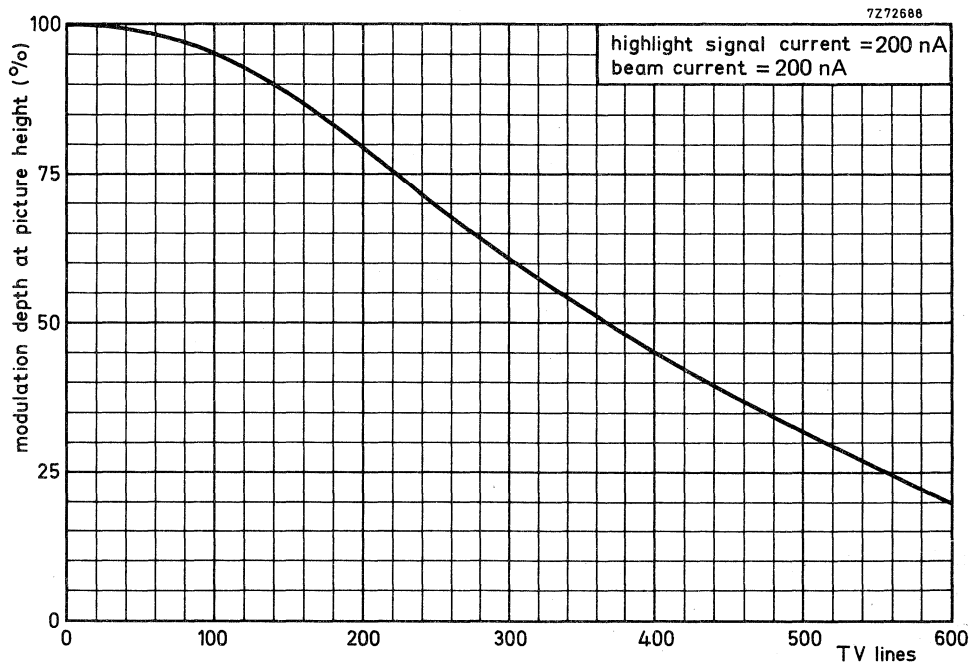

Fig. 3 Typical uncompensated square wave response curve.

CAMERA TUBE

NEWWICON[®] television camera tube with a photoconductive target composed of cadmium and zinc tellurides featuring high resolution and an extremely high sensitivity.

The XQ1442 is a 1 in diameter camera tube with low heater power, separate mesh, magnetic focusing and deflection, a fibre optic faceplate, and is mechanically and electrically interchangeable with the Newvicon tube type XQ1440.

The XQ1442 is intended for use in low light level cameras, in which it is coupled directly to a fibre optic output window of an image intensifier, for scientific, industrial, surveillance and security applications.

QUICK REFERENCE DATA

Separate mesh			
Focusing		magnetic	
Deflection		magnetic	
Diameter		25,9	mm
Length		159	mm
Faceplate		fibre optic	
Spectral response, max. at	approx.	750	nm
cut-off at	approx.	900	nm
Heater		6,3 V, 95	mA
Limiting resolution		650	TV lines

OPTICAL

Diagonal of quality rectangle on photoconductive layer (aspect ratio 3 : 4) 16 mm

Orientation of image on photoconductive layer

The direction of the horizontal scan should be essentially parallel to the plane passing through the longitudinal tube axis and the short index pin.

Spectral response curve see Fig. 1

Faceplate

thickness 3,0 mm
refractive index 1,00

HEATING

Indirect by a.c. or d.c. parallel or series supply

Heater voltage V_f 6,3 V \pm 10%

Heater current, at $V_f = 6,3$ V I_f 95 mA

When the tube is used in a series heater chain, the heater voltage must not exceed an r.m.s. value of 9,5 V when the supply is switched on.

[®]Registered trade mark for television camera tubes.

CAPACITANCES

Signal electrode to all

$$C_{as} \approx 4,6 \text{ pF}$$

This capacitance, which is effectively the output impedance of the tube, increases when the tube is inserted into the deflection and focusing coil unit.

MECHANICAL DATA

Dimensions in mm

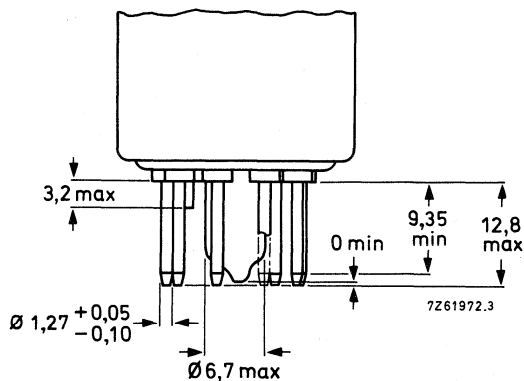
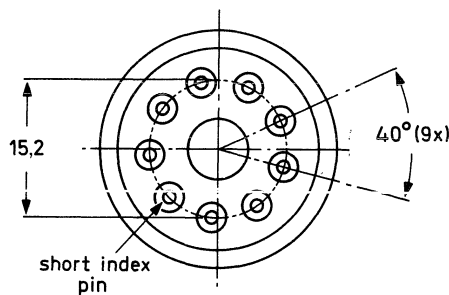
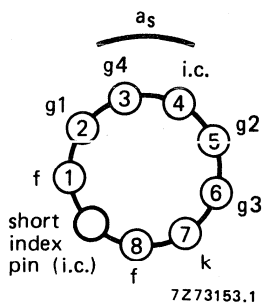
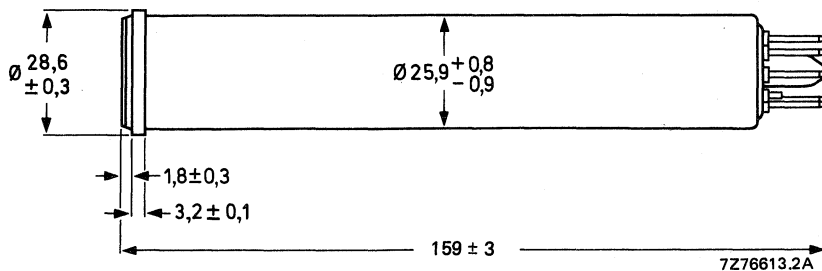

Base: JEDEC no. E8-11

Mounting position: any

Net mass: $\approx 62 \text{ g}$

ACCESSORIES

Socket	56602 or equivalent
Deflection and focusing coil unit	KV9G or equivalent

DEFLECTION magnetic

FOCUSING magnetic

LIMITING VALUES (Absolute maximum rating system)
for a scanned area of 9,6 mm x 12,8 mm.

'Full-size scanning' i.e. scanning of a 9,6 mm x 12,8 mm area of the photoconductive layer should always be applied. Underscanning i.e. scanning of an area smaller than 9,6 mm x 12,8 mm, may cause permanent damage to the specified full-size area.

Signal electrode voltage	V_{as}	max	50 V*
Grid 4 voltage	V_{g4}	max	1000 V
Grid 3 voltage	V_{g3}	max	1000 V
Grid 2 voltage	V_{g2}	max	750 V
Grid 1 voltage, negative	$-V_{g1}$	max	300 V
positive	V_{g1}	max	0 V
Cathode-to-heater voltage, peak positive	V_{kfp}	max	125 V
peak negative	$-V_{kfp}$	max	10 V
Output current, peak	I_{asp}	max	800 nA**
Faceplate illumination	E	max	10 000 lx [▲]
Faceplate temperature, storage and operation	T	max	70 °C
Cathode heating time before drawing cathode current	t_h	min	1 min

* Newwicon tubes do not permit automatic sensitivity control by means of regulation of the signal electrode voltage. Adequate control is therefore to be achieved by other means (iris control and neutral density filters). If the tube is applied in cameras originally designed for vidicon tubes, the automatic sensitivity control circuitry should be made inoperative and the signal electrode voltage set to the value indicated by the tube manufacturer. See General Operational Notes.

** Video amplifiers should be capable of handling signal electrode currents of this magnitude without overloading the amplifier or distorting the picture.

▲ White light, uniformly diffused over entire tube face. Care must be taken not to focus the solar image on the target through a lens opening wider than f: 11 to avoid instantaneous breakdown.

OPERATING CONDITIONS AND PERFORMANCE

for a scanned area of 9,6 mm x 12,8 mm, a faceplate temperature of 25 to 35 °C and standard TV scanning rate.

Conditions				notes
Signal electrode voltage	V_{as}	10 to 25 V		1
Grid 4 (decelerator) voltage	V_{g4}	500 V		2
Grid 3 (beam focus electrode) voltage	V_{g3}	300 V		3
Grid 2 (accelerator) voltage	V_{g2}	300 V		
Grid 1 voltage picture cut-off (no blanking applied)	V_{g1}	-100 to -45 V		
Blanking voltage, peak to peak				
when applied to grid 1			75 V	
when applied to cathode			20 V	
Flux density at centre of focusing coil			3,8 to 4,4 mT	
Flux density of adjustable alignment coil or magnet			0 to 0,4 mT	
Performance				
Dark current (at 25 °C)		min.	typ.	max.
			7	16 nA
Signal current, white light				
faceplate illuminance 0,5 lx, c.t. 2856 K	I_s	140	180	nA
Decay: residual signal current 60 ms after				
cessation of the illumination (c.t. 2856 K),				
initial signal current 200 nA			17	22 %
Limiting resolution,				
at picture centre		550	650	TV lines 4
at picture corners			450	TV lines 4
Average γ of transfer characteristic			≈ 1	
Spurious signals (spots and blemishes)				5

Notes

1. The signal electrode voltage should be adjusted to the value indicated by the tube manufacturer as printed on the envelope ($E_{sj} = \dots V$).
To minimize picture sticking effects the signal electrode voltage should be adjusted within a tolerance accuracy of $\pm 2 V$, the voltage drop across R_1 should be kept small. In the case of cathode blanking, the voltage drop across the cathode resistor during read-out should be taken into account.
2. Grid 4 voltage must always be higher than grid 3 voltage. The recommended ratio of grid 4 voltage to grid 3 voltage both for best geometry and most uniform signal output depends upon the type of coil unit used and will be 5 : 3 for the recommended types (see "Accessories").
3. Resolution decreases with decreasing grid 3 voltage. In general grid 3 should be operated above 250 V.
4. On EIA resolution test chart; faceplate illumination adjusted for a peak output current of 200 nA.
5. **Conditions**

The camera focused on a uniformly illuminated two-zone test pattern, the diameter of the centre zone (1) being equal to the raster height. Zone (2) being defined as the remainder of the scanned area.

Faceplate illumination adjusted to produce 200 nA signal current, beam current adjusted for correct stabilization.

Monitor set-up and contrast control adjusted for faint raster when lens of camera is capped and for non-blooming bright raster when lens of camera is uncapped.

Under the above conditions the number and size of spots per zone visible in the monitor picture, under both capped and uncapped conditions will not exceed the limits stated below. Both black and white spots must be counted unless their contrast is less than 10% of peak white signal as observed on a waveform oscilloscope.

Background lines, originating from the structure of the fibre optic faceplate will have a contrast of $\leq 25\%$ of peak white signal and will not exceed a width of 0,4%, or a length of 6% of picture height.

	spot size in % of raster height	maximum number of spots	
		zone 1	zone 2
white and black spots	$> 1,4$	none	none
	$\leq 1,4$ to 0,8	none	1
	$\leq 0,8$ to 0,6	2	3
white spots	$\leq 0,6$ to 0,2	4	6
	$\leq 0,2$	*	*
black spots	$\leq 0,6$ to 0,4	8	10
	$\leq 0,4$	*	*

* Do not count spots of this size unless concentration causes a smudgy appearance.

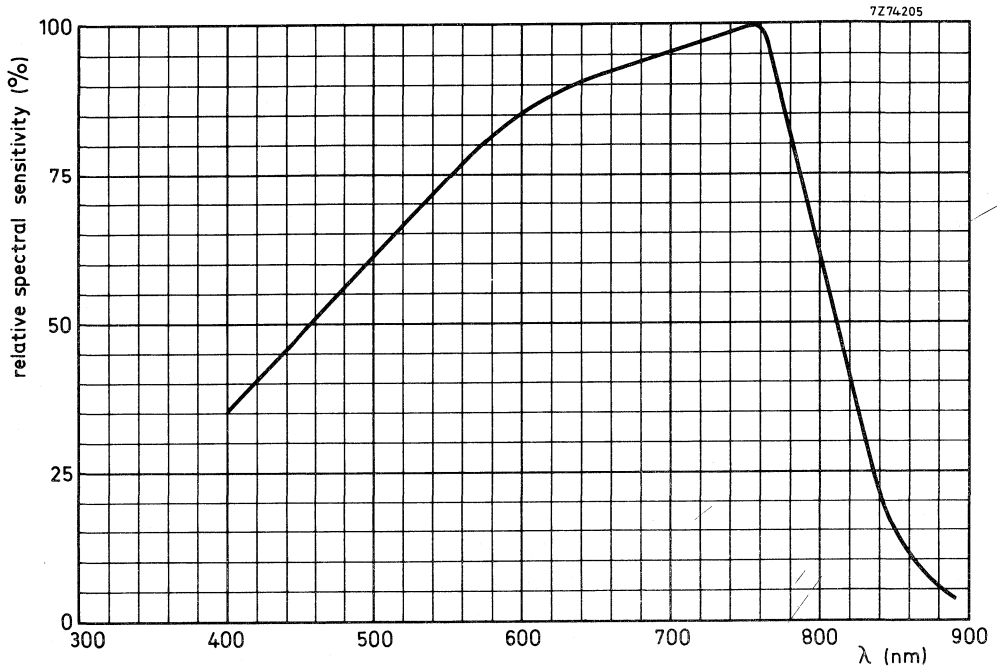

Fig.1 Typical spectral response curve.

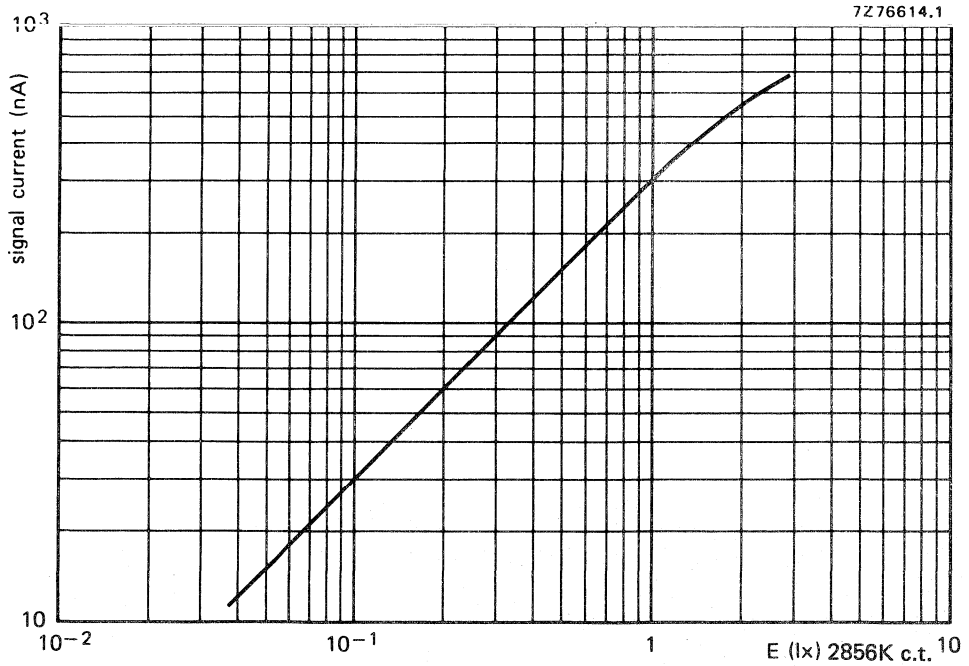

Fig.2 Typical light transfer characteristic.

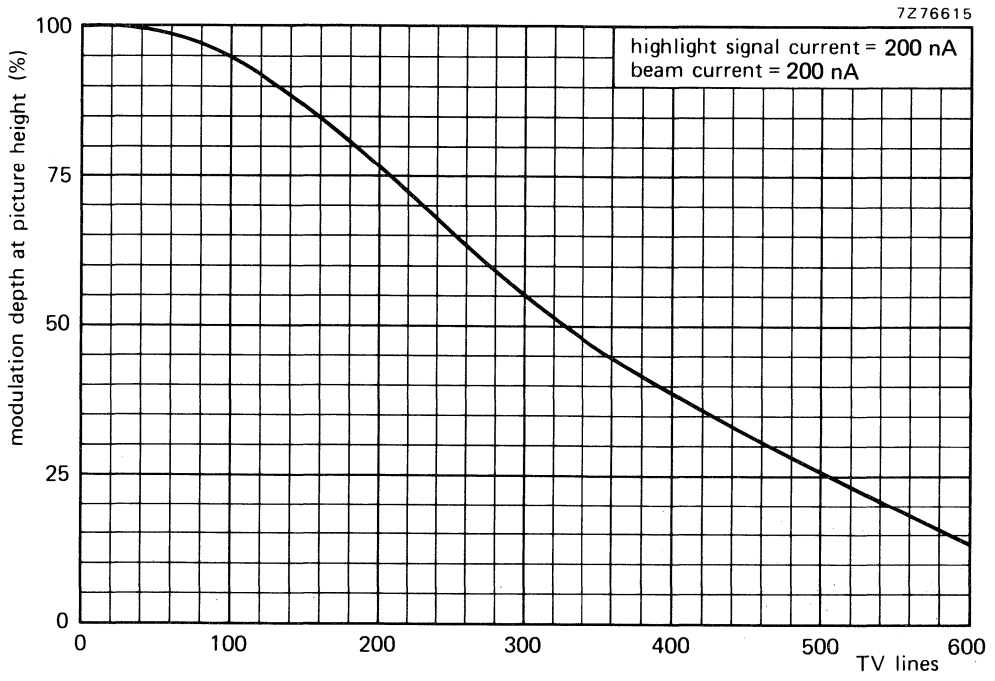

Fig.3 Typical uncompensated square-wave response curve.

CAMERA TUBE

NEWVICON® television camera tube with a photoconductive target composed of cadmium and zinc tellurides featuring high resolution and an extremely high sensitivity extending into the near infrared region.

The XQ1443 is a 1 in diameter camera tube with low heater power, separate mesh, magnetic focusing and deflection, and is mechanically interchangeable with vidicons like the XQ1240/XQ1241 and Newvicon tube XQ1440 and has the same pin connections.

The XQ1443 is intended for use in ultra-sensitive cameras for security and surveillance applications, for example, where its high sensitivity extending into the near infrared, and its high resolution, small size and low power consumption are essential.

QUICK REFERENCE DATA

Separate mesh	
Focusing	magnetic
Deflection	magnetic
Diameter	25,9 mm
Length	159 mm
Spectral response, max. at	approx. 775 nm
Spectral response, cut-off at	approx. 1000 nm
Heater	6,3 V, 95 mA
Limiting resolution	750 TV lines

OPTICAL

Diagonal of quality rectangle on photoconductive layer
(aspect ratio 3 : 4)

16 mm

Orientation of image on photoconductive layer:

The direction of the horizontal scan should be essentially parallel to the plane passing through the longitudinal tube axis and the short index pin.

Faceplate

thickness

2,5 mm

refractive index

1,61

Spectral response curve see Fig. 1

HEATING

Indirect by a.c. or d.c.; parallel or series supply

Heater voltage

V_f 6,3 V \pm 10%

Heater current at $V_f = 6,3$ V

I_f 95 mA

When the tube is used in a series heater chain, the heater voltage must not exceed an r.m.s. value of 9,5 V when the supply is switched on.

® Registered trade mark for television camera tubes.

CAPACITANCES

Signal electrode to all

$$C_{as} \approx 4,6 \text{ pF}$$

This capacitance, which is effectively the output impedance of the tube, increases when the tube is inserted in the deflection and focusing coil unit.

MECHANICAL DATA

Dimensions in mm

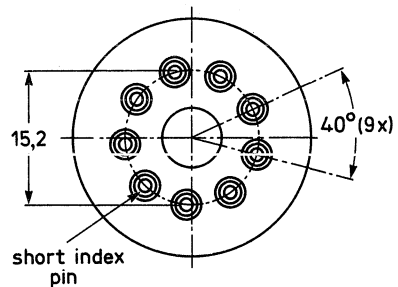
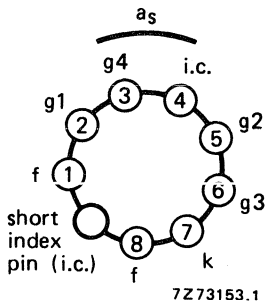
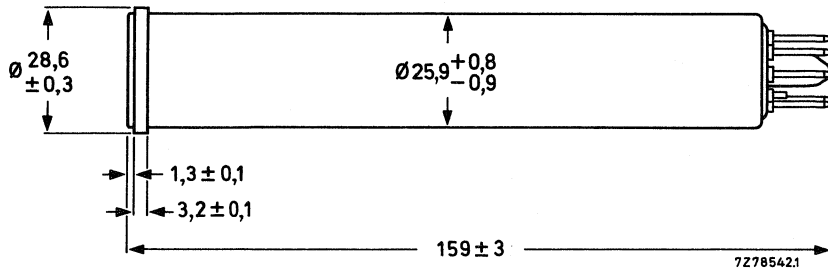

BASE PIN CONNECTIONS (Bottom view)

- Pin 1 heater
- Pin 2 grid 1
- Pin 3 grid 4
- Pin 4 i.c. (internally connected)
- Pin 5 grid 2
- Pin 6 grid 3
- Pin 7 cathode
- Pin 8 heater
- Short index pin i.c.
- Flange target (signal electrode)

Mounting position any

Net mass $\approx 70 \text{ g}$

Base JEDEC No. E8-11

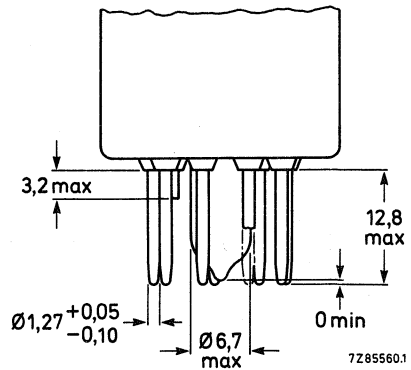

ACCESSORIES

Socket	type 56602 or equivalent
Deflection and focusing coil unit	KV9G or equivalent

DEFLECTION

magnetic

FOCUSING

magnetic

LIMITING VALUES (Absolute maximum rating system)
for a scanned area of 9,6 mm x 12,8 mm.

'Full-size scanning' i.e. scanning of a 9,6 mm x 12,8 mm area of the photoconductive layer should always be applied. Underscanning, i.e. scanning of an area smaller than 9,6 mm x 12,8 mm, may cause permanent damage to the specified full-size area.

Signal electrode voltage	V_{as}	max.	50 V *
Grid 4 voltage	V_{g4}	max.	1000 V
Grid 3 voltage	V_{g3}	max.	1000 V
Grid 2 voltage	V_{g2}	max.	750 V
Grid 1 voltage, negative	$-V_{g1}$	max.	300 V
Grid 1 voltage, positive	V_{g1}	max.	0 V
Cathode-to-heater voltage, peak positive	V_{kfp}	max.	125 V
Cathode-to-heater voltage, peak negative	$-V_{kfp}$	max.	10 V
Output current, peak	I_{asp}	max.	800 nA**
Faceplate illumination	E	max.	10 000 lx [▲]
Faceplate temperature, storage and operation	T	max.	60 °C
Cathode heating time before drawing cathode current	t_h	min.	1 min

* Newvicon tubes do not permit automatic sensitivity control by means of regulation of the signal electrode voltage. Adequate control is therefore to be achieved by other means (iris control and neutral density filters). If the tube is applied in cameras originally designed for vidicon tubes, the automatic sensitivity control circuitry should be made inoperative and the signal electrode voltage set to the value indicated by the tube manufacturer. See General Operational Notes.

** Video amplifiers should be capable of handling signal-electrode currents of this magnitude without overloading the amplifier or distorting the picture.

▲ White light, uniformly diffused over entire tube face.

Care must be taken not to focus the solar image on the target through a lens opening wider than f : 11 to avoid instantaneous breakdown.

OPERATING CONDITIONS AND PERFORMANCE

for a scanned area of 9,6 mm x 12,8 mm and a faceplate temperature of 25 to 35 °C and standard TV scanning rate.

Conditions

			notes
Signal electrode voltage	V_{as}	10 to 25 V	1
Grid 4 (decelerator) voltage	V_{g4}	500 V	2
Grid 3 (beam focus electrode) voltage	V_{g3}	300 V	3
Grid 2 (accelerator) voltage	V_{g2}	300 V	
Grid 1 voltage for picture cut-off (no blanking applied)	V_{g1}	-100 to -45 V	
Blanking voltage, peak to peak			
when applied to grid 1		75 V	
when applied to cathode		25 V	
Flux density at centre of focusing coil		3,8 to 4,4 mT	
Flux density of adjustable alignment coil or magnet		0 to 0,4 mT	

Performance

		min.	typ.	max.
Dark current (at 25 °C)			8	15 nA
Signal current, white light faceplate illumination 0,5 lx c.t. 2856 K	I_s	240	270	nA
Signal current, near infrared illumination 0,5 lx, c.t. 2856 K infrared transmitting filter interposed (transmission curve see Fig. 2)	I_s	50	75	nA
Decay: residual signal current 60 ms after cessation of the illumination (c.t. 2856 K) initial signal current 200 nA			17	%
Limiting resolution, at picture centre		650	750	TV lines 4
Limiting resolution, at picture corners		400	500	TV lines 4
Average γ of transfer characteristic			≈ 1	
Spurious signals (spots and blemishes)				5

Notes

1. The signal electrode voltage should be adjusted to the value indicated by the tube manufacturer as printed on the envelope ($E_{sj} = \dots V$).
To minimize picture sticking effects the signal electrode voltage should be adjusted within a tolerance of $\pm 2 V$; the voltage drop across R_1 should be kept small. In case of cathode blanking the voltage drop across the cathode resistor during read-out should be taken into account.
2. Grid 4 voltage must always be higher than grid 3 voltage. The recommended ratio of grid 4 voltage to grid 3 voltage both for best geometry and most uniform signal output depends upon the type of coil unit used and will be 5 : 3 for the recommended type (see 'Accessories').
3. Resolution decreases with decreasing grid 4 voltage. In general grid 3 should be operated above 250 V.
4. On EIA resolution test chart; faceplate illumination adjusted for a peak output current of 200 nA.

5. Conditions

The camera focused on a uniformly illuminated two-zone test pattern, the diameter of the centre zone (1) being equal to the raster height. Zone (2) being defined as the remainder of the scanned area.

Faceplate illumination adjusted to produce 200 nA signal current, beam current adjusted for correct stabilization.

Monitor set-up and contrast control adjusted for faint raster when lens of camera is capped and for non-blooming bright raster when lens of camera is uncapped.

Under above conditions the number and size of spots per zone as visible in the monitor picture will not exceed the limits stated below. Both black and white spots must be counted, unless their contrast is less than 50% of peak white signal as observed on a waveform oscilloscope. Spots having a contrast $\geq 100\%$ are fully counted, spots having a contrast $> 50\%$ but $< 100\%$ will be considered as having half their actual size.

spot size in % of raster height	maximum number of spots	
	zone 1	zone 2
$> 1,2$	none	none
$\leq 1,2$ to 0,8	none	1
$\leq 0,8$ to 0,4	4	5
$\leq 0,4$ to 0,2	5	5
$\leq 0,2$	*	*
total (max.)	5	7

* Do not count spots of this size unless concentration causes a smudgy appearance.

Tubes are rejected for: smudges, lines, streaks, mottled, grainy or uneven background having contrast $> 50\%$.

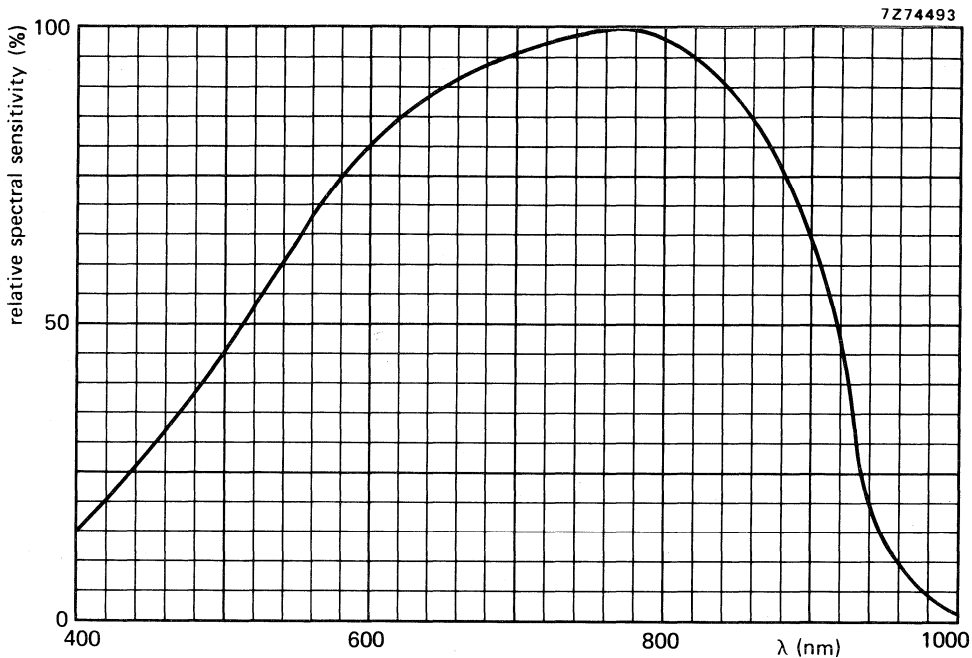

Fig. 1 Typical spectral response curve, C2.

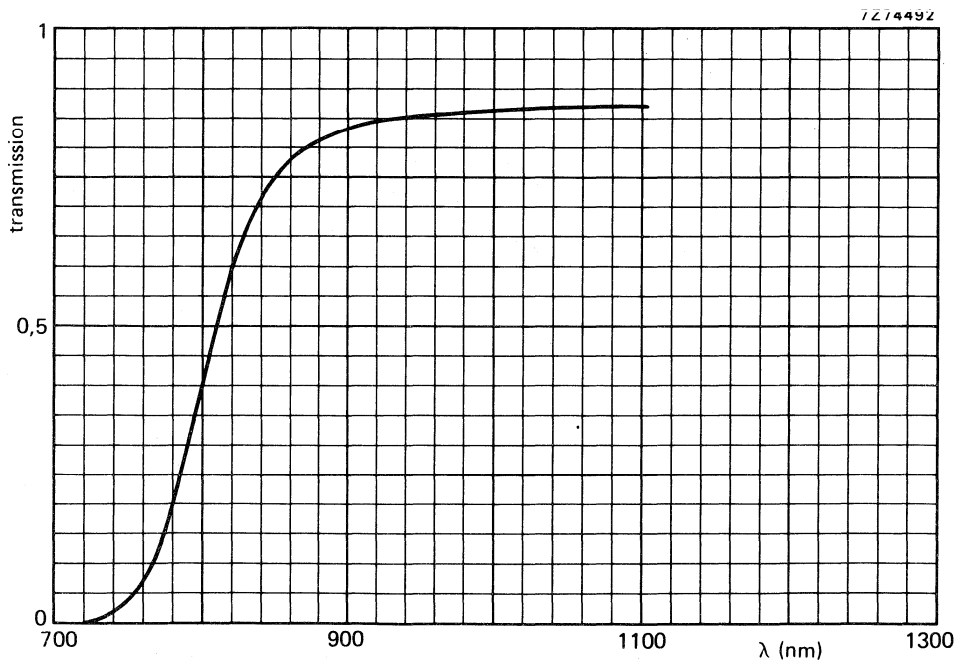

Fig. 2 Transmission curve of infrared filter (Hoya IR80).

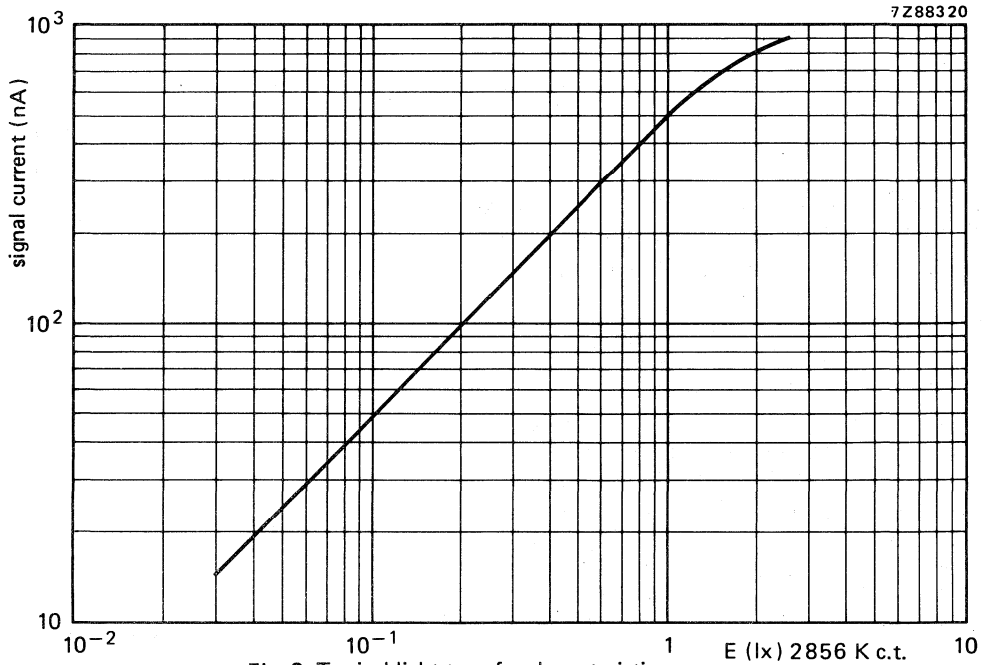

Fig. 3 Typical light transfer characteristic.

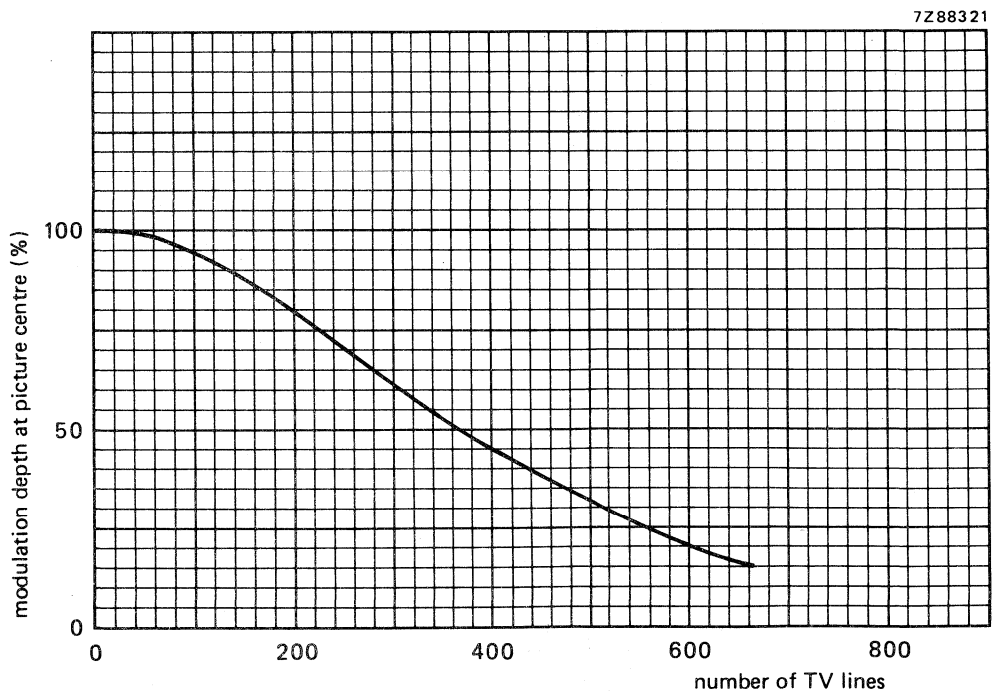

Fig. 4 Typical uncompensated square wave response curve. Highlight signal current 200 nA, beam current 200 nA.

CAMERA TUBE

Newvicon® camera tube, mechanically and electron-optically identical to the XQ1440, the major difference being the radiation resistant (anti-browning) faceplate.

The XQ1444 is intended for use in cameras which are subjected to high doses of ionizing radiation.

RADIATION RESISTANT FACEPLATE

The faceplate of the XQ1444 is made of a special type of glass and does not turn brown under the influence of high doses of gamma radiation.

- Maximum dose rate per hour: 5×10^5 Röntgen/hour
- Maximum cumulative dose: 5×10^7 Röntgen
- Maximum decrease of transmission of faceplate:

Maximum decrease	After a cumulative dose of
3%	10^5 Röntgen
10%	10^6 Röntgen
15%	5×10^7 Röntgen

- Maximum increase of dark current at 25 °C after a cumulative dose of 5×10^7 Röntgen: 75%

SENSITIVITY

The typical sensitivity of the XQ1444 is approximately 10% less than for the XQ1440.

For all other information see data of XQ1440.

CAMERA TUBE

Newvicon® camera tube, electrically and electron-optically identical to the XQ1440; the only difference being the overall length.

The XQ1445 is intended for use in cameras for security and surveillance, where its high sensitivity and resolution, low power consumption and short length are essential.

For the electrical and mechanical data of the XQ1445 refer to those of the XQ1440.

MECHANICAL DATA

Dimensions in mm

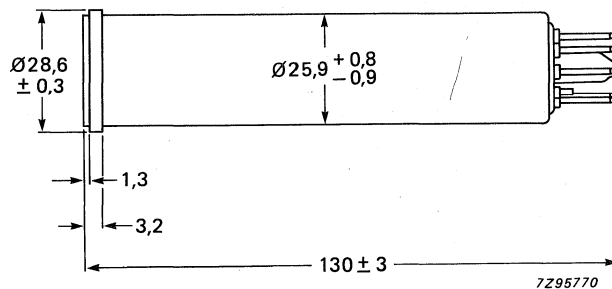

ACCESSORIES

Deflection and focusing coil unit

KV9G or equivalent

CAMERA TUBE

NEWVICON® television camera tube with a photoconductive target composed of cadmium and zinc tellurides featuring high resolution and an extremely high sensitivity.

The XQ1601 is a ½ in diameter camera tube with very low heater power, separate mesh, electrostatic focusing and magnetic deflection. It is mechanically interchangeable with vidicons like XQ1600 and has the same pin connections.

The XQ1601 is intended for use in ultra-compact cameras for security and surveillance applications, for example, where its high sensitivity and resolution, small size and low power consumption are essential.

QUICK REFERENCE DATA

Separate mesh		
Focusing		electrostatic
Deflection		magnetic
Diameter		13,5 mm
Length	max.	85 mm
Spectral response, max. at cut-off at	approx.	750 nm
	approx.	900 nm
Heater		2,8 V, 107 mA
Limiting resolution		450 TV lines

OPTICAL

Diagonal of quality rectangle on photoconductive layer (aspect ratio 3 : 4) 7,75 mm

Orientation of image on photoconductive layer:

The direction of the horizontal scan should be essentially parallel to the plane passing through the short index pin and the longitudinal axis of the tube.

Spectral response, curve see Fig. 1

Faceplate

thickness 1,6 mm
refractive index 1,611

HEATING Indirect by a.c. or d.c.; parallel or series supply

Heater voltage V_f 2,8 V ± 5%

Heater current, at $V_f = 2,8$ V I_f 107 mA ± 10%

When the tube is used in a series heater chain, the heater voltage must not exceed an r.m.s. value of 3,5 V when the supply is switched on.

CAPACITANCES

Signal electrode to all

$$C_{as} \approx 1,5 \text{ pF}$$

This capacitance, which is effectively the output impedance of the tube, increases when the tube is inserted into the deflection coil unit.

MECHANICAL DATA

Dimensions in mm

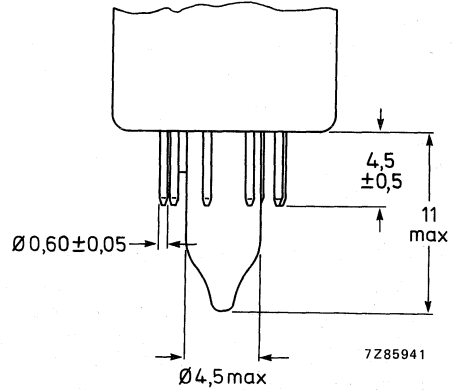
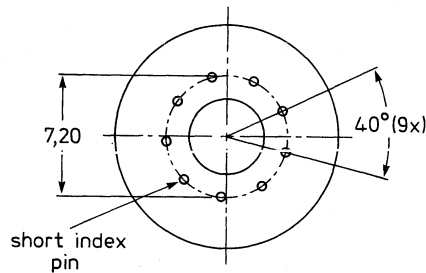
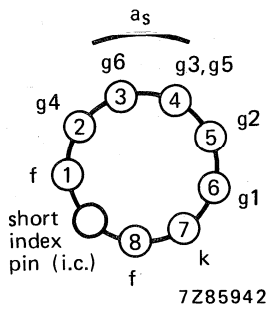
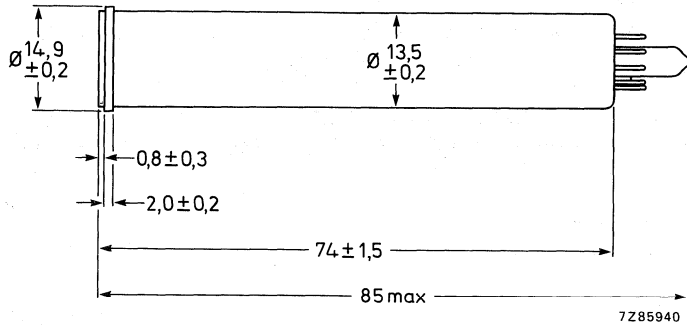

Mounting position: any

Net mass: $\approx 12 \text{ g}$

ACCESSORIES

Socket	special miniature 8-pin, type 56600 or equivalent
Deflection coil unit	KV29E or equivalent

DEFLECTION

magnetic

FOCUSING

electrostatic

LIMITING VALUES

(Absolute maximum rating system) for scanned area of 4,65 mm x 6,2 mm.

"Full-size scanning" i.e. scanning of a 4,65 mm x 6,2 mm area of the photoconductive layer should always be applied. Underscanning, i.e. scanning of an area smaller than 4,65 mm x 6,2 mm, may cause permanent damage to the specified full-size area.

Signal electrode voltage	V_{as}	max.	50 V*
Grid 6 voltage	V_{g6}	max.	600 V
Grid 4 (beam focus electrode) voltage	V_{g4}	max.	350 V
Grid 3 and 5 voltage	$V_{g3,g5}$	max.	450 V
Grid 2 voltage	V_{g2}	max.	400 V
Grid 1 voltage, negative	$-V_{g1}$	max.	300 V
positive	V_{g1}	max.	0 V
Cathode-to-heater voltage peak positive	V_{kfp}	max.	125 V
peak negative	$-V_{kfp}$	max.	10 V
Output current, peak	I_{asp}	max.	500 nA**
Faceplate illumination	E	max.	10 000 lx ▲
Faceplate temperature, storage and operation	T	max.	70 °C
Cathode heating time before drawing cathode current	t_h	min.	1 min

* Newvicon tubes do not permit automatic sensitivity control by means of regulation of the signal electrode voltage. Adequate control is therefore to be achieved by other means (iris control and neutral density filters). If the tube is applied in cameras originally designed for vidicon tubes, the automatic sensitivity control circuitry should be made inoperative and the signal electrode voltage set to the value indicated in the test sheet. See General Operational Notes.

** Video amplifiers should be capable of handling signal electrode currents of this magnitude without overloading the amplifier or distorting the picture.

▲ White light, uniformly diffused over entire tube face.

Care must be taken not to focus the solar image on the target through a lens opening wider than $f : 11$ to avoid instantaneous breakdown.

OPERATING CONDITIONS AND PERFORMANCE

For a scanned area of 4,65 mm x 6,2 mm, a faceplate temperature of 25 to 35 °C and standard TV scanning rate.

Conditions

			notes
Signal electrode voltage	V_{as}	10 to 35 V	1
Grid 6 (decelerator) voltage	V_{g6}	500 V	2
Grid 4 (beam focus electrode) voltage	V_{g4}	31 to 55 V	3
Grid 3 and 5 voltage	V_{g3+5}	250 V	2
Grid 2 voltage	V_{g2}	300 V	
Grid 1 voltage for picture cut off (no blanking applied)	V_{g1}	-100 to -40 V	
Blanking voltage, peak to peak			
when applied to grid 1		75 V	
when applied to cathode		20 V	
Flux density of adjustable alignment coil or magnet		0 to 0,4 mT	

Performance

	min.	typ.	max.	
Dark current (at 25 °C)		3	4,5	nA
Signal current, white light faceplate illumination 1 lx c.t. 2856 K	I_s 90	110		nA
Decay: residual signal current 60 ms after cessation of the illumination initial signal current 100 nA		10		%
Limiting resolution at picture centre		480		TV lines 4
Average γ of transfer characteristic		≈ 1		
Spurious signals (spots and blemishes)				5

Notes

1. The signal electrode voltage should be adjusted to the value indicated by the tube manufacturer as printed on the envelope ($V_{esi} = \dots V$). To minimize picture sticking effects the signal electrode should be adjusted within a tolerance of $\pm 2 V$; the voltage drop across R_1 should be kept small. In the case of cathode blanking the voltage drop across the cathode resistor during read-out should be taken into account.
2. Grid 6 voltage must always be higher than grids 3 + 5 voltage.
The recommended ratio of grid 6 voltage to grids 3 + 5 voltage for best geometry and most uniform signal output depends upon the type of coil used and will be 2 : 1 for the recommended type (see "Accessories").
3. Adjusted for correct electrical focus.
4. On EIA resolution test chart: faceplate illumination adjusted for a peak output current of 100 nA. The resolution is highly dependent on the coil used; the indicated figures are only valid for the recommended coil.

5. Conditions

The camera focused on a uniformly illuminated two-zone test pattern, the diameter of the centre zone (1) being equal to the raster height. Zone (2) being defined as the remainder of the scanned area.

Faceplate illumination adjusted to produce 100 nA signal current, beam current adjusted for correct stabilization.

Monitor set-up and contrast control adjusted for faint raster when lens of camera is capped and for non-blooming bright raster when lens of camera is uncapped.

Under above conditions the number and size of spots per zone visible in the monitor picture will not exceed the limits stated below. Both black and white spots must be counted, unless their contrast is less than 50% of peak white signal as observed on a waveform oscilloscope. Spots having a contrast $\geq 100\%$ are fully counted, spots having a contrast $> 50\%$ but $< 100\%$ will be considered as having half their actual size.

Spot size in % of raster height	Maximum number of spots	
	zone 1	zone 2
$> 1,2$	none	none
$\leq 1,2$ to 0,8	none	1
$\leq 0,8$ to 0,4	4	5
$\leq 0,4$ to 0,2	5	5
$\leq 0,2$	*	*
total (max.)	5	7

* Do not count spots of this size unless concentration causes a smudgy appearance.
Tubes are rejected for: smudges, lines, streaks, mottled, grainy or uneven background having contrast $> 50\%$.

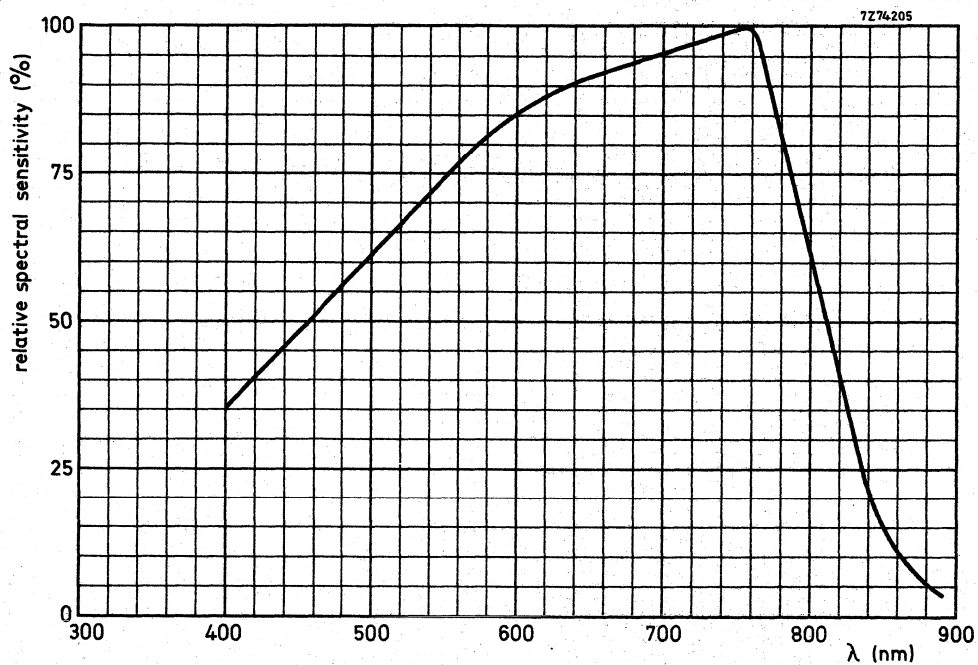

Fig. 1 Typical spectral response curve.

CAMERA TUBE

Newvicon® camera tube, mechanically and electron-optically identical to the XQ1601, the major difference being the radiation resistant (anti-browning) faceplate.

The XQ1602 is intended for use in cameras which are subjected to high doses of ionizing radiation.

RADIATION RESISTANT FACEPLATE

The faceplate of the XQ1602 is made of a special type of glass and does not turn brown under the influence of high doses of gamma radiation.

- Maximum dose rate per hour: 5×10^5 Röntgen/hour
- Maximum cumulative dose: 5×10^7 Röntgen
- Maximum decrease of transmission of faceplate:

Maximum decrease	After a cumulative dose of
3%	10^5 Röntgen
10%	10^6 Röntgen
15%	5×10^7 Röntgen

- Maximum increase of dark current at 25 °C after a cumulative dose of 5×10^7 Röntgen: 75%

SENSITIVITY

The typical sensitivity of the XQ1602 is approximately 10% less than for the XQ1601.

For all other information see data of XQ1601.

DEFLECTION UNITS

DEFLECTION UNIT FOR 1-inch VIDICON**QUICK REFERENCE DATA**

	inductance	resistance
Line deflection coils	1,6 mH	4,4 Ω
Frame deflection coils	70 mH	120 Ω
Focus coil	—	100 Ω

APPLICATION

The KV9G is for use in black and white cameras using front-loading 1-inch camera tubes.

DESCRIPTION

The deflection unit consists of deflection, focus coils and alignment ring magnets for 25 mm (1-inch) diameter vidicon, Newvicon® and similar television camera tubes (e.g. XQ1031, XQ1240, XQ1241 and XQ1440).

CATALOGUE NUMBER

The catalogue number is 9390 288 80000.

Dimensions in mm

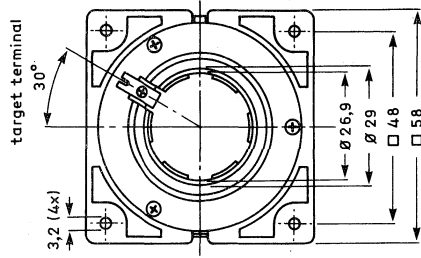

7286070A

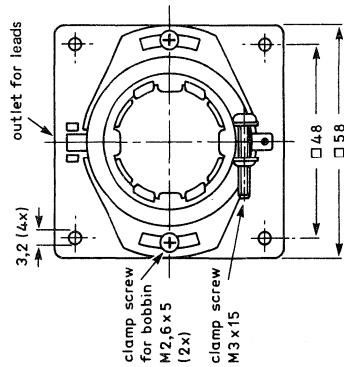
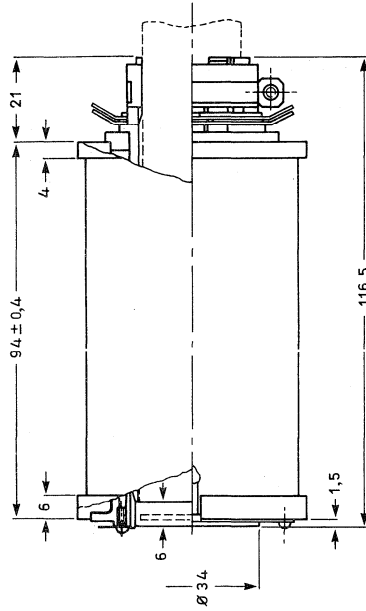

MECHANICAL DATA

Leads

- Line deflection coil red-blue
 - Frame deflection coil green-yellow
 - Focus coil brown-white
- Length from rear of unit 190 ± 10 mm
 The ends of the leads are stripped for 5 mm

Mass 500 g approx.

Alignment ring magnets

Magnet rotation torque (with one ring fixed) 0,007 to 0,20 Nm

Flux density

- max. 0,4 mT
- min. 0,05 mT

Operating temperature -10 to +60 °C

ELECTRICAL DATA

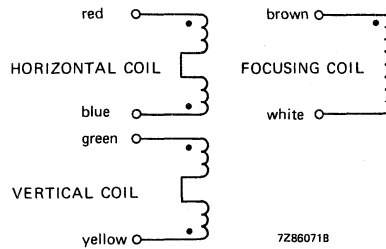

coils	inductance mH	resistance Ω
line deflection	$1,6 \pm 10\%$	$4,4 \pm 10\%$
frame deflection	$70 \pm 10\%$	$120 \pm 10\%$
focus*		$100 \pm 10\%$

Required currents for normal operation

Line deflection, peak-peak	150 mA \pm 5%
Frame deflection, peak-peak	33 mA \pm 5%
Focus current, at 4 mT	90 mA \pm 10%

Insulation resistance

Between coils, and between coils and earth, at 100 V d.c. > 50 M Ω

Geometric distortion

Barrel, keystone and pin cushion distortion are within 2% of picture height

Skew: $90^\circ \pm 2^\circ$ (4% of picture height).

* If a positive voltage is applied to the brown lead, the north-seeking pole of a compass should be attracted to the image end of the unit.

DEFLECTION UNIT FOR $\frac{2}{3}$ -inch CAMERA TUBES**QUICK REFERENCE DATA**

	inductance	resistance
Line deflection coils	0,88 mH	2,9 Ω
Frame deflection coils	32 mH	146 Ω
Focus coil		55 Ω

APPLICATION

The KV12S is for use in black and white cameras using front loading $\frac{2}{3}$ -inch camera tubes.

DESCRIPTION

The deflection unit consists of deflection and focusing coils and alignment ring magnets for 17,7 mm ($\frac{2}{3}$ -inch) vidicon, Newvicon® and similar camera tubes (e.g. XQ1270, XQ1271, XQ1274).

CATALOGUE NUMBER

The catalogue number is 9390 258 20000.

MECHANICAL DATA

Dimensions in mm

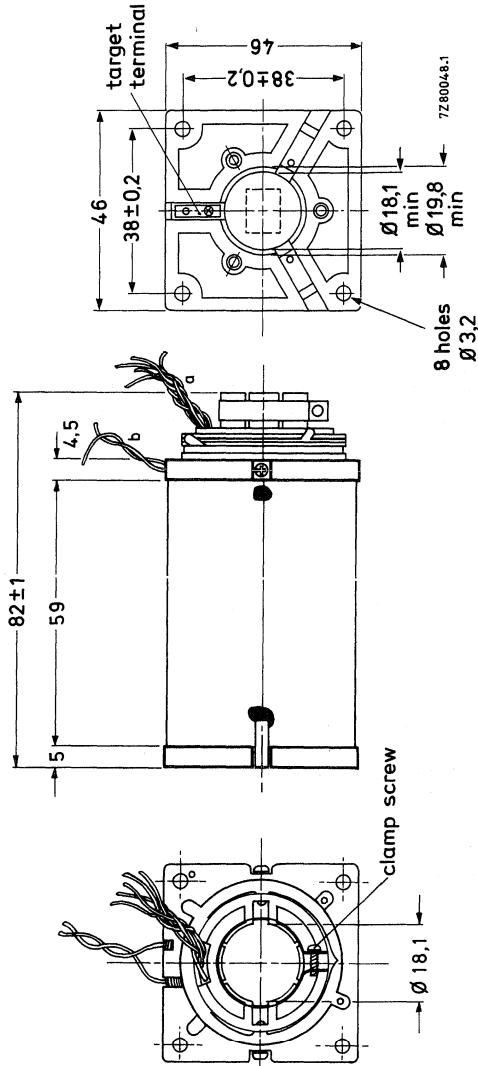

Leads

- Line deflection coil red-blue
- Frame deflection coil green-yellow
- Focusing coil brown-white
- Shield black

Length from rear of unit 190 ± 10 mm

The ends of the leads are stripped for 5 mm

Mass

approx. 290 g

Alignment ring magnets

Magnet rotation torque (with one ring fixed) 0,005 to 0,15 Nm

Flux density

max. 0,4 mT

min. 0,05 mT

Operating temperature

-10 to +60 °C

ELECTRICAL DATA

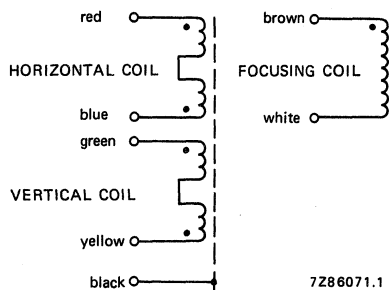

coils	inductance mH	resistance Ω
line deflection coils	$0,88 \pm 10\%$	$2,9 \pm 10\%$
frame deflection coils	$32 \pm 10\%$	$146 \pm 10\%$
focusing coil*		$55 \pm 10\%$

Required currents for normal operation

Line deflection, peak-peak	$150 \text{ mA} \pm 5\%$
Frame deflection, peak-peak	$20 \text{ mA} \pm 5\%$
Focusing, at 5 mT	$120 \text{ mA} \pm 10\%$

Insulation resistance

Between coils, and between coils and earth shield, at 100 V d.c.	$>50 \text{ M}\Omega$
--	-----------------------

Geometric distortion

Barrel, keystone and pin cushion distortion are within 2% at picture height.
Skew: $90^\circ \pm 2^\circ$ (4% of picture height).

* If a positive voltage is applied to the brown lead, the north-seeking pole of a compass should be attracted to the image end of the unit.

DEFLECTION UNIT FOR $\frac{2}{3}$ -inch CAMERA TUBES

with electrostatic focusing

QUICK REFERENCE DATA

	inductance	resistance
Line deflection coils	0,9 mH	4,4 Ω
Frame deflection coils	26 mH	145 Ω

APPLICATION

The KV19G is for use in black and white cameras using front loading $\frac{2}{3}$ -inch camera tubes.

DESCRIPTION

The deflection unit consists of deflection coils and alignment ring magnets for 17,7 mm ($\frac{2}{3}$ -inch) vidicon, Newvicon[®] and similar camera tubes (e.g. XQ1272, XQ1275).

CATALOGUE NUMBER

The catalogue number is 9390 271 20000.

[®] Registered trade mark for television camera tubes.

MECHANICAL DATA

Dimensions in mm

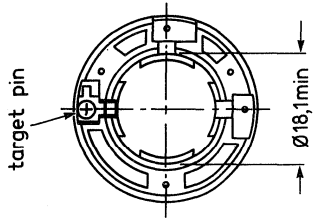
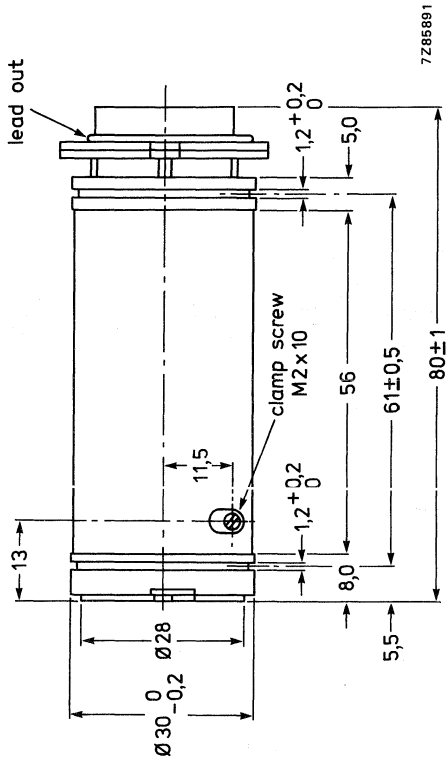
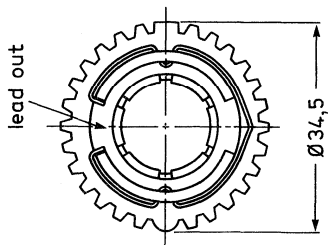

Leads

- Line deflection coil red-blue
- Frame deflection coil green-yellow
- Shield black

Length from rear of unit 190 ± 10 mm

The ends of the leads are stripped for 5 mm

Mass

approx. 50 g

Alignment ring magnets

Magnet rotation torque (with one ring fixed) 0,01 to 0,1 Nm

Flux density

max. 0,4 mT
min. 0,03 mT

Operating temperature

-10 to +60 °C

ELECTRICAL DATA

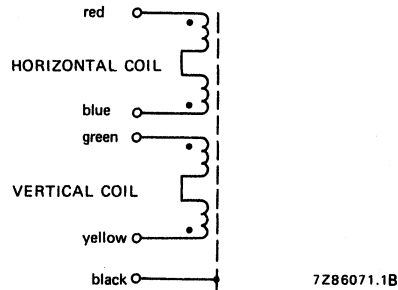

coils	inductance mH	resistance Ω
line deflection coils	$0,9 \pm 10\%$	$4,4 \pm 10\%$
frame deflection coils	$26 \pm 10\%$	$145 \pm 10\%$

Required currents for normal operation

Line deflection, peak-peak	100 mA \pm 5%
Frame deflection, peak-peak	16 mA \pm 5%

Insulation resistance

Between coils, and between coils and earth shield	>50 M Ω
---	----------------

Geometric distortion

Barrel, keystone and pin cushion distortion within 2% of picture height.

Skew: $90^\circ \pm 2^\circ$ (4% of picture height).

DEFLECTION UNIT FOR $\frac{2}{3}$ -inch CAMERA TUBES

with electrostatic focusing

QUICK REFERENCE DATA

	inductance	resistance
Line deflection coils	0,9 mH	4,6 Ω
Frame deflection coils	24,6 mH	147 Ω

APPLICATION

The KV19N is for use in black and white cameras using front-loading $\frac{2}{3}$ -inch camera tubes.

DESCRIPTION

The deflection unit consists of deflection coils and alignment ring magnets for 17,7 mm ($\frac{2}{3}$ -inch) diameter Vidicon, Newvicon[®] and similar television camera tubes (e.g. XQ1272, XQ1275).

CATALOGUE NUMBER

The catalogue number is 9390 312 20000.

[®] Registered trade mark for television camera tubes.

MECHANICAL DATA

Dimensions in mm

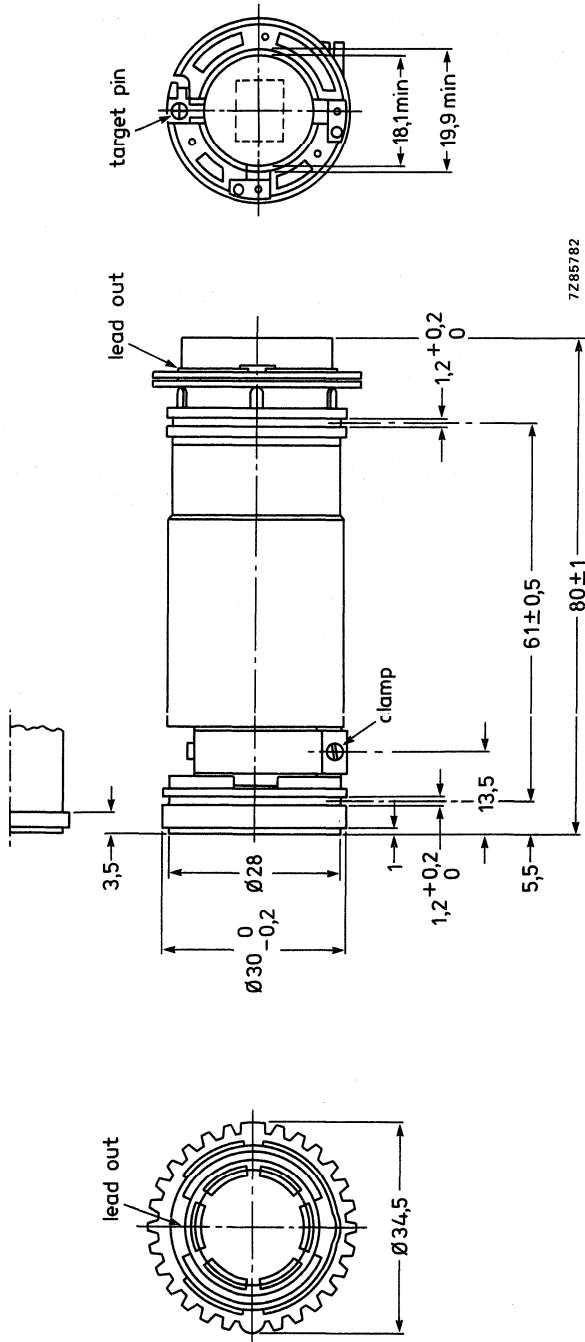

Leads

Line deflection coil red-blue
 Frame deflection coil green-yellow
 Length from rear of unit 190 ± 10 mm
 The ends of the leads are stripped for 5 mm

Mass 50 g approx.

Alignment ring magnets

Magnet rotation torque (with one ring fixed) 0,01 to 0,1 Nm

Flux density

max. 0,4 mT

min. 0,03 mT

Operating temperature -10 to $+60$ °C

ELECTRICAL DATA

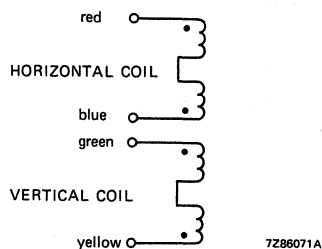

coils	inductance mH	resistance Ω
line deflection	$0,9 \pm 10\%$	$4,6 \pm 10\%$
frame deflection	$24,6 \pm 10\%$	$147 \pm 10\%$

Required currents for normal operation

Line deflection, peak-peak	100 mA \pm 5%
Frame deflection, peak-peak	16 mA \pm 5%

Insulation resistance

Between coils, and between coils and earth shield, at 100 V d.c. > 50 M Ω

Geometric distortion

Barrel, keystone and pin cushion distortion are within 2% of picture height.

Skew: $90^\circ \pm 2^\circ$ (4% of picture height).

DEFLECTION UNIT FOR $\frac{2}{3}$ -inch CAMERA TUBES**QUICK REFERENCE DATA**

	inductance	resistance
Line deflection coils	0,86 mH	3,2 Ω
Frame deflection coils	28 mH	146 Ω
Focus coil	—	55 Ω

APPLICATION

The KV22B is for use in black and white cameras using front-loading $\frac{2}{3}$ -inch camera tubes.

DESCRIPTION

The deflection unit consists of deflection, focus coils and alignment ring magnets for 17,7 mm ($\frac{2}{3}$ -inch) diameter vidicon, Newvicon[®] and similar television camera tubes (e.g. XQ1270, XQ1271 and XQ1274).

CATALOGUE NUMBER

The catalogue number is 9390 299 10000.

[®] Registered trade mark for television camera tubes.

MECHANICAL DATA

Dimensions in mm

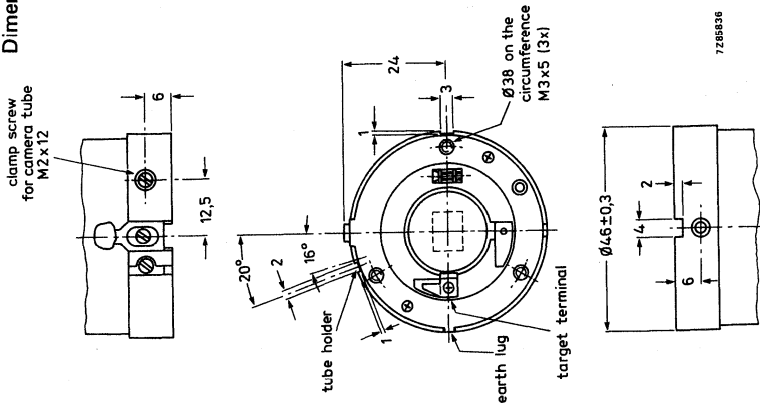

7285838

- Leads**
 - Line deflection coil red-blue
 - Frame deflection coil green-yellow
 - Focus coil brown-white
 - Shield black
 - Length from rear of unit 190 ± 10 mm
- The ends of the leads are stripped for 5 mm

- Mass** 280 g approx.
- Alignment ring magnets**
- Magnet rotation torque (with one ring fixed) 0,005 to 0,15 Nm
- Flux density
max. 0,5 mT
min. 0,1 mT

Operating temperature -10 to +60 °C

ELECTRICAL DATA

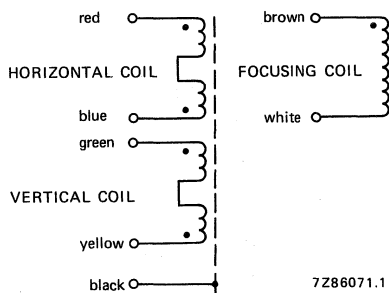

coils	inductance mH	resistance Ω
line deflection	$0,86 \pm 7\%$	$3,2 \pm 10\%$
frame deflection	$28 \pm 10\%$	$146 \pm 10\%$
focus*		$55 \pm 10\%$

Required currents for normal operation

Line deflection, peak-peak	$150 \text{ mA} \pm 5\%$
Frame deflection, peak-peak	$20 \text{ mA} \pm 5\%$
Focus, at 5 mT	$120 \text{ mA} \pm 10\%$

Insulation resistance

Between coils, and between coils and shield, at 100 V d.c. $> 50 \text{ M}\Omega$

Geometric distortion

Barrel, keystone and pin cushion distortion are within 2% of picture height.

Skew: 90 degrees ± 2 degrees (4% of picture height).

* If a positive voltage is applied to the brown lead, the north-seeking pole of a compass should be attracted to the image end of the unit.

DEFLECTION UNIT FOR ½-inch CAMERA TUBES

with electrostatic focusing

QUICK REFERENCE DATA

	inductance	resistance
Line deflection coils	1,4 mH	11,3 Ω
Frame deflection coils	5,7 mH	60,7 Ω

APPLICATION

The KV29E is for use in black and white cameras using front-loading ½-inch camera tubes.

DESCRIPTION

The deflection unit consists of deflection coils and alignment ring magnets for 13,5 mm (½-inch) diameter Vidicon, Newvicon® and similar television camera tubes (e.g. XQ1600, XQ1601).

CATALOGUE NUMBER

The catalogue number is 9390 300 90000.

MECHANICAL DATA

Dimensions in mm

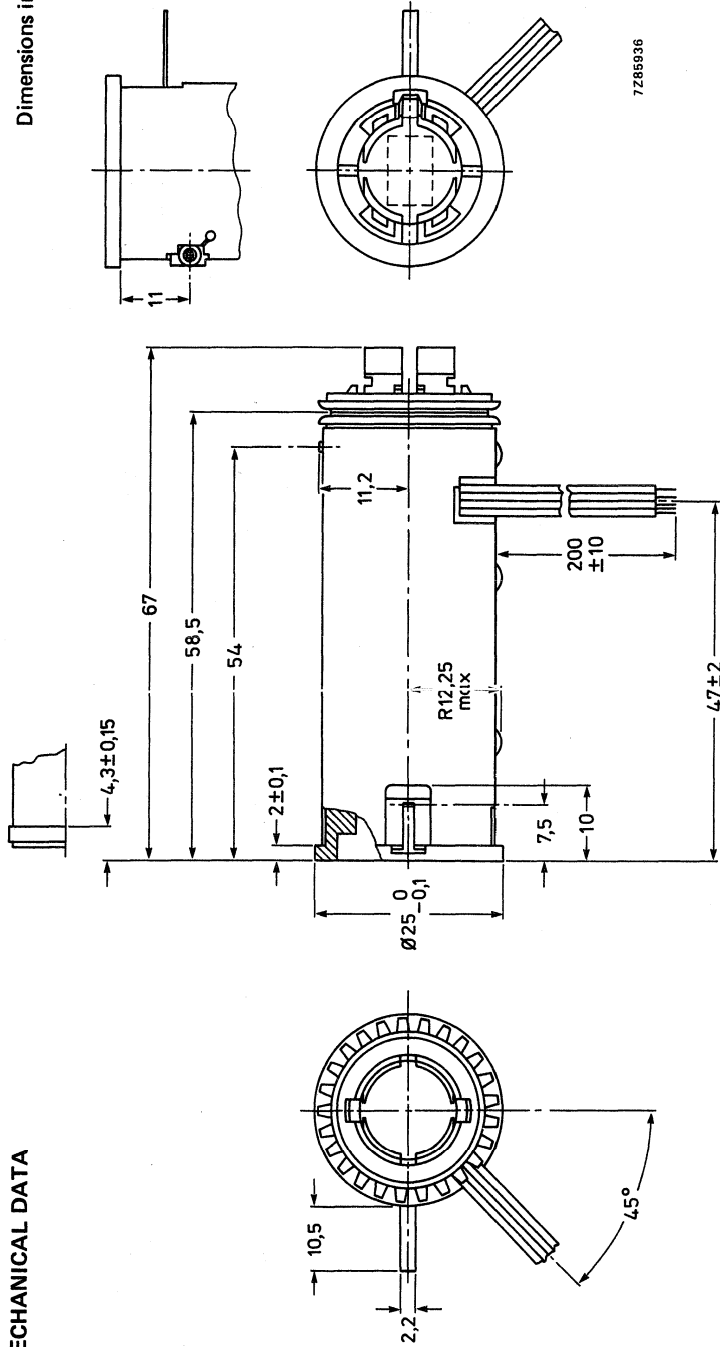

Leads

- Line deflection coil red-blue
- Frame deflection coil orange-yellow
- Shield green
- Length from rear of unit 200 ± 10 mm
- The ends of the leads are stripped for 5 mm

Mass 22 g approx.

Alignment ring magnets

- Magnet rotation torque (with one ring fixed) 0,01 to 0,1 Nm
- Flux density
 - max. 0,5 mT
 - min. 0,04 mT

Operating temperature -10 to +60 °C

ELECTRICAL DATA

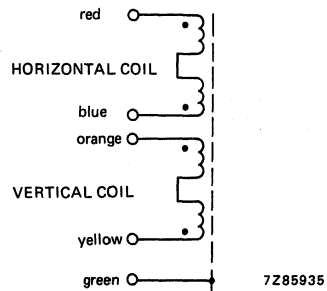

coils	inductance mH	resistance Ω
line deflection	$1,4 \pm 10\%$	$11,3 \pm 10\%$
frame deflection	$5,7 \pm 10\%$	$60,7 \pm 10\%$

Required currents for normal operation

Line deflection, peak-peak

70 mA \pm 5%

Frame deflection, peak-peak

26 mA \pm 5%**Insulation resistance**

Between coils, and between coils and earth shield, at 100 V d.c.

> 50 M Ω **Geometric distortion**

Barrel, keystone and pin cushion distortion are within 1,5% of picture height.

Skew: $90^\circ \pm 1^\circ$ (2% of picture height).

INDEX OF TYPE NUMBERS

type	kind*	page	type	kind*	page
KV9G	D	155	XQ1277	N	105
KV12S	D	159	XQ1278	N	111
KV19G	D	163	XQ1280	V	39
KV19N	D	167	XQ1285	V	51
KV22B	D	171	XQ1380	N	117
KV29E	D	175	XQ1381	N	118
XQ1031	V	9	XQ1440	N	119
XQ1032	V	9	XQ1442	N	127
XQ1240	V	15	XQ1443	N	135
XQ1241	V	15	XQ1444	N	142
XQ1270	V	21	XQ1445	N	143
XQ1271	V	27	XQ1590	V	63
XQ1272	V	33	XQ1600	V	69
XQ1274	N	81	XQ1601	N	145
XQ1275	N	89	XQ1602	N	151
XQ1276	N	97			

For Plumbicon television camera tubes see relevant Data Handbook.

* V = vidicon tube
 N = Newvicon tube
 D = deflection unit.

NOTES

NOTES

NOTES

NOTES

NOTES

DATA HANDBOOK SYSTEM

DATA HANDBOOK SYSTEM

Our Data Handbook System comprises more than 60 books with specifications on electronic components, subassemblies and materials. It is made up of six series of handbooks:

INTEGRATED CIRCUITS

DISCRETE SEMICONDUCTORS

DISPLAY COMPONENTS

PASSIVE COMPONENTS*

PROFESSIONAL COMPONENTS**

MATERIALS*

The contents of each series are listed on pages iii to viii.

The data handbooks contain all pertinent data available at the time of publication, and each is revised and reissued periodically.

When ratings or specifications differ from those published in the preceding edition they are indicated with arrows in the page margin. Where application is given it is advisory and does not form part of the product specification.

Condensed data on the preferred products of Philips Components is given in our Preferred Type Range catalogue (issued annually).

Information on current Data Handbooks and how to obtain a subscription for future issues is available from any of the Organizations listed on the back cover.

Product specialists are at your service and enquiries will be answered promptly.

* Will replace the Components and materials (green) series of handbooks.

** Will replace the Electron tubes (blue) series of handbooks.

INTEGRATED CIRCUITS

This series of handbooks comprises:

code	handbook title
IC01	Radio, audio and associated systems Bipolar, MOS
IC02a/b	Video and associated systems Bipolar, MOS
IC03	ICs for Telecom Bipolar, MOS Subscriber sets, Cordless Telephones
IC04	HE4000B logic family CMOS
IC05	not yet issued
IC06	High-speed CMOS; PC74HC/HCT/HCU Logic family
IC07	Advanced CMOS logic (ACL)
IC08	ECL 10K and 100K logic families
IC09N	TTL logic series
IC10	Memories MOS, TTL, ECL
IC11	Linear Products
Supplement to IC11	Linear Products
IC12	I²C-bus compatible ICs
IC13	Semi-custom Programmable Logic Devices (PLD)
IC14	Microcontrollers Bipolar, MOS
IC15	FAST TTL logic series
IC16	CMOS integrated circuits for clocks and watches
IC17	ICs for Telecom Bipolar, MOS Radio pagers Mobile telephones ISDN
IC18	Microprocessors and peripherals
IC19	Data communication products

DISCRETE SEMICONDUCTORS

This series of data handbooks comprises:

current code	new code	handbook title
S1	SC01	Diodes High-voltage tripler units
S2a	SC02*	Power diodes
S2b	SC03*	Thyristors and triacs
S3	SC04*	Small-signal transistors
S4a	SC05*	Low-frequency power transistors and hybrid IC power modules
S4b	SC06	High-voltage and switching power transistors
S5	SC07*	Small-signal field-effect transistors
S6	SC08*	RF power transistors
	SC09*	RF power modules
S7	SC10*	Surface mounted semiconductors
S8a	SC11*	Light emitting diodes
S8b	SC12*	Optocouplers
S9	SC13*	PowerMOS transistors
S10	SC14*	Wideband transistors and wideband hybrid IC modules
S11	SC15	Microwave transistors
S15**	SC16	Laser diodes
S13	SC17	Semiconductor sensors
S14	SC18*	Liquid crystal displays and driver ICs for LCDs

* Not yet issued with the new code in this series of handbooks.

** New handbook in this series; will be issued shortly.

DISPLAY COMPONENTS

This series of data handbooks comprises:

current code	new code	handbook title
T8	DC01	Colour display systems
T16	DC02*	Monochrome tubes and deflection units
C2	DC03*	Television tuners, coaxial aerial input assemblies
C3	DC04*	Loudspeakers
C20	DC05*	Wire-wound components for TVs and monitors

* These handbooks are currently issued in another series; they are not yet issued in the Display Components series of handbooks.

PASSIVE COMPONENTS

This series of data handbooks comprises:

current code	new code	handbook title
C14	PA01	Electrolytic capacitors; solid and non-solid
C11	PA02*	Varistors, thermistors and sensors
C12	PA03*	Potentiometers, encoders and switches
C7	PA04*	Variable capacitors
C22	PA05*	Film capacitors
C15	PA06*	Ceramic capacitors
C9	PA07*	Piezoelectric quartz devices
C13	PA08*	Fixed resistors

* Not yet issued with the new code in this series of handbooks.

PROFESSIONAL COMPONENTS

This series of data handbooks comprises:

current code	new code	handbook title
T1	*	Power tubes for RF heating and communications
T2a	*	Transmitting tubes for communications, glass types
T2b	*	Transmitting tubes for communications, ceramic types
T3	PC01**	High-power klystrons
T4	*	Magnetrons for microwave heating
T5	PC02**	Cathode-ray tubes
T6	PC03**	Geiger-Müller tubes
T9	PC04**	Photo and electron multipliers
T10	PC05**	Plumbicon camera tubes and accessories
T11	PC06**	Microwave diodes and sub-assemblies
T12	PC07	Vidicon and Newvicon camera tubes and deflection units
T13	PC08	Image intensifiers
T15	PC09**	Dry reed switches
C8	PC10	Variable mains transformers; annular fixed transformers
	PC11	Solid state image sensors and peripheral integrated circuits

* These handbooks will not be reissued.

** Not yet issued with the new code in this series of handbooks.

MATERIALS

This series of data handbooks comprises:

current code	new code	handbook title
C4 } C5 }	MA01*	Soft Ferrites
C16	MA02**	Permanent magnet materials
C19	MA03**	Piezoelectric ceramics

* Handbooks C4 and C5 will be reissued as one handbook having the new code MA01.

** Not yet issued with the new code in this series of handbooks.

Philips Components – a worldwide Group of Companies

Argentina: PHILIPS ARGENTINA S.A., Div. Philips Components, Vedia 3892, 1430 BUENOS AIRES, Tel. (01) 541-4261.

Australia: PHILIPS COMPONENTS PTY Ltd, 11 Waltham Street, ARTARMON, N.S.W. 2064, Tel. (02) 439 3322.

Austria: ÖSTERREICHISCHE PHILIPS INDUSTRIE G.m.b.H., UB Bauelemente, Triester Str. 64, 1101 WIEN, Tel. (0222) 60 101-820.

Belgium: N.V. PHILIPS PROF. SYSTEMS – Components Div., 80 Rue Des Deux Gares, B-1070 BRUXELLES, Tel. (02) 52 56 111.

Brazil: PHILIPS COMPONENTS (Active Devices): Av. Brigadeiro Faria Lima, 1735-SAO PAULO-SP, Tel. (011) 211-2600. PHILIPS COMPONENTS (Passive Devices & Materials): Av. Francisco Monteiro, 702-RIBEIRO PICES-SP, Tel. (011) 459-8211.

Canada: PHILIPS ELECTRONICS LTD., Philips Components, 601 Milner Ave., SCARBOROUGH, Ontario, M1B 1M8, Tel. (416) 292-5161.

Chile: PHILIPS CHILENA S.A., Av. Santa Maria 0760, SANTIAGO, Tel. (02) 77 38 16.

Colombia: IPRELENCO LTDA., Carrera 21 No. 56-17, BOGOTA, D.E., P.O. Box 77621, Tel. (01) 249 7624.

Denmark: PHILIPS COMPONENTS A/S, Prags Boulevard 80, PB 1919, DK-2300 COPENHAGEN S, Tel. (01)-54 11 33.

Finland: PHILIPS COMPONENTS, Sinikalliontie 3, SF-2630 ESPOO HELSINKI 10, Tel. 358-0-50261.

France: PHILIPS COMPOSANTS RTC-COMPELEC, 117 Quai du Président Roosevelt, 92134 ISSY-LES-MOULINEAUX Cedex, Tel. (01) 40 93 80 00.

Germany (Fed. Republic): VALVO, UB Bauelemente der Philips G.m.b.H., Valvo Haus, Burchardstrasse 19, D-2 HAMBURG 1, Tel. (040) 3296-0.

Greece: PHILIPS HELLENIQUE S.A., Components Division, No. 15, 25th March Street, GR 17778 TAVROS, Tel. (01) 4894 339/4894 311.

Hong Kong: PHILIPS HONG KONG LTD., Components Div., 15/F Philips Ind. Bldg., 24-28 Kung Yip St., KWAI CHUNG, Tel. (0)-24 61 21.

India: PEICO ELECTRONICS & ELECTRICALS LTD., Components Dept., Band Box Building, 254-D Dr. Annie Besant Rd., BOMBAY – 400 025, Tel. (022) 49 30 311/49 30 590.

Indonesia: P.T. PHILIPS-RALIN ELECTRONICS, Components Div., Setiabudi II Building, 6th Fl., Jalan H.R. Rasuna Said (P.O. Box 223/KBY) Kuningan, JAKARTA 12910, Tel. (021) 51 79 95.

Ireland: PHILIPS ELECTRONICS (IRELAND) LTD., Components Division, Newstead, Clonskeagh, DUBLIN 14, Tel. (01) 69 33 55.

Italy: PHILIPS S.p.A., Philips Components, Piazza IV Novembre 3, I-20124 MILANO, Tel. (02) 6752-1.

Japan: PHILIPS K.K. Philips Components Division, Philips Bldg 13-37, Kohnan 2-chome, Minato-ku, TOKYO (108), Tel. (03) 740 5028.

Korea (Republic of): PHILIPS ELECTRONICS (KOREA) LTD., Components Division, Philips House, 260-199 Itaewon-dong, Yongsan-ku, SEOUL, Tel. (02) 794-5011.

Malaysia: PHILIPS MALAYSIA SDN BHD, Components Div., 3 Jalan SS15/2A SUBANG, 47500 PETAJONG JAYA, Tel. (03) 73 45 511.

Mexico: PHILIPS COMPONENTS, Paseo Triunfo de la Republica, No 215 Local 5, Cd Juarez CHIHUAHUA 32340 MEXICO Tel. (16) 18-67-01/02

Netherlands: PHILIPS NEDERLAND, Marktgroep Philips Components, Postbus 90050, 5600 PB EINDHOVEN, Tel. (040) 78 37 49.

New Zealand: PHILIPS NEW ZEALAND LTD., Components Division, 110 Mt. Eden Road, C.P.O. Box 1041, AUCKLAND, Tel. (09) 605-914.

Norway: NORSK A/S PHILIPS, Philips Components, Box 1, Manglerud 0612, OSLO, Tel. (02) 68 02 00.

Pakistan: PHILIPS ELECTRICAL CO. OF PAKISTAN LTD., Philips Markaz, M.A. Jinnah Rd., KARACHI-3, Tel. (021) 72 57 72.

Peru: CADESA, Av. Pardo y Aliaga No. 695, 6th Floor, San Isidro, LIMA 100, P.O. Box 5612, Tel. (014) 70 70 80.

Philippines: PHILIPS INDUSTRIAL DEV. INC., 2246 Pasong Tamo, P.O. Box 911, Makati Comm. Centre, MAKATI-RIZAL 3116, Tel. (02) 86 89 51 to 59.

Portugal: PHILIPS PORTUGUESA S.A.R.L., Av. Eng. Duarte Pacheco 6, 1009 LISBOA Codex, Tel. (019) 68 31 21.

Singapore: PHILIPS PROJECT DEV. (Singapore) PTE LTD., Components Div., Lorong 1, Toa Payoh, SINGAPORE 1231, Tel. 35 02 000.

Spain: PHILIPS Components, Balmes 22, 08007 BARCELONA, Tel. (03) 301 63 12.

Sweden: PHILIPS Components, A.B., Tegeluddsvägen 1, S-11584 STOCKHOLM, Tel. (08)-78 21 000.

Switzerland: PHILIPS A.G., Components Dept., Allmendstrasse 140-142, CH-8027 ZÜRICH, Tel. (01) 488 22 11.

Taiwan: PHILIPS TAIWAN LTD., 150 Tun Hua North Road, P.O. Box 22978, TAIPEI, Taiwan, Tel. (02) 71 20 500.

Thailand: PHILIPS ELECTRICAL CO. OF THAILAND LTD., 283 Silom Road, P.O. Box 961, BANGKOK, Tel. (02) 233-6330-9.

Turkey: TURK PHILIPS TICARET A.S., Philips Components, Talatpasa Cad. No. 5, 80640 LEVENT/ISTANBUL, Tel. (01) 179 27 70.

United Kingdom: PHILIPS COMPONENTS LTD., Mullard House, Torrington Place, LONDON WC1E 7HD, Tel. (01) 580 6633.

United States: (Active Devices & Materials) AMPEREX Electronic Corporation, Providence Pike, SLATERSVILLE, R.I. 02876, Tel. (401) 762-9000.

(Colour picture tubes – Monochrome & Colour Display Tubes) PHILIPS DISPLAY COMPONENTS, 50 Johnston St., SENECA FALLS, N.Y. 13148, Tel. (315) 568-5881. (IC Products) SIGNETICS CORPORATION, 811 East Arques Avenue, SUNNYVALE, CA 94088-3409, Tel. (408) 991-2000. (Passive & Electromech. Dev.) MEPCO/CENTRALAB, INC., 2001 West Blue Heron Blvd, RIVIERA BEACH, Florida 33404, P.O. Box 10330, Tel. (407) 881-3200.

Uruguay: PHILIPS COMPONENTS, Coronel Mora 433, MONTEVIDEO, Tel. (02) 70-4044.

Venezuela: MAGNETICA S.A., Calle 6, Ed. Las Tres Jotas, CARACAS 1074A, App. Post. 78117, Tel. (02) 241 75 09.

Zimbabwe: PHILIPS ELECTRICAL (PVT) LTD., 62 Mutare Road, HARARE, P.O. Box 994, Tel. 47211

For all other countries apply to: Philips Components Division, International Business Relations, P.O. Box 218, 5600 MD EINDHOVEN, The Netherlands, Telex 35000 phctnl

AS69

© Philips Export B.V. 1989

All rights are reserved. Reproduction in whole or in part is prohibited without the prior written consent of the copyright owner.

The information presented in this document does not form part of any quotation or contract, is believed to be accurate and reliable and may be changed without notice. No liability will be accepted by the publisher for any consequence of its use. Publication thereof does not convey nor imply any license under patent- or other industrial or intellectual property rights.

Printed in The Netherlands

9398 161 20011

Philips Components



PHILIPS